

Displacement Sensor  
**CD Series**

**High Performance Multi Head  
Laser Displacement Sensor**  
CD5 series

**Laser Displacement Sensor**  
CD4 series CD4L-25 series

**Laser Displacement Sensor : CMOS system**  
CD33 series

**Laser Displacement Sensor : CMOS system**  
CD3 series

**Laser Displacement Sensor : PSD system**  
CD1 series



## DISPLACEMENT SENSOR LINEUP

World's largest variety of displacement sensors designed in compact dimensions and convenience for PC communication.

- Specifications are subject to change without prior notice.
- Specifications and technical information not mentioned here are written in Operation Manual. Or visit our website for details.
- All the warnings and cautions to know prior to use are given in Operation Manual.

# CD SERIES LINE UP

## 3 page CD5 series

### Sensor head

Model	Type	Light source	Measuring range (mm)	Linearity	Resolution
CD5-L25	Narrow	IEC Class 2 FDA CLASS II	25±1	±0.08% F.S.	0.02μm
CD5-LW25	Wide				
CD5-30	Narrow		30±5	±0.08% F.S.	0.2μm
CD5-W30	Wide				
CD5-85	Narrow		85±20	±0.05% F.S.	1μm
CD5-W85	Wide				
CD5-W350	Wide		350±100	±0.08% F.S.	5μm
CD5-W500	Wide		500±200	±0.08% F.S.	10μm
CD5-W2000	Wide		IEC Class 3R FDA CLASS IIIa	2000±500	±0.1% F.S.

### Controller

Model	Number of connected sensor heads	Output	Sensor heads
CD5A-N	Max. 3pcs	±10V / F.S., 4-20mA / F.S. RS-232C, USB	CD5 series heads
CD5A-P			

## 19 page CD4 series

### Sensor head

Model	Type	Light source	Measuring range (mm)	Linearity	Resolution
CD4-30	Regular	Class 2 (IEC/JIS), CLASS II (FDA)	30±5	±0.1% F.S.	1μm
CD4-30-3R	High power	Class 3R (IEC/JIS), CLASS IIIa (FDA)			
CD4-85	Regular	Class 2 (IEC/JIS), CLASS II (FDA)	85±20		3μm
CD4-85-3R	High power	Class 3R (IEC/JIS), CLASS IIIa (FDA)			
CD4-350	Regular	Class 2 (IEC/JIS), CLASS II (FDA)	350±100		40μm
CD4-350-3R	High power	Class 3R (IEC/JIS), CLASS IIIa (FDA)			

Model	Type	Light source	Measuring range	Linearity	Resolution
CD4L-25	Specular	Class 1 (IEC/JIS) CLASS II (FDA) Laser, 650nm, Max 390 Micro W	25±1	±0.1% F.S.	0.1μm

### Controller

Model	Number of connected sensor heads	Output	Sensor heads
CD4A-N	Max. 2pcs	±5V / F.S., 4-20mA / F.S. RS-232C	CD4 series heads
CD4A-P			
CD4A-LN			CD4L-25 series heads
CD4A-LP			

## 31 page CD33 series

Model	Type	Light source	Measuring range (mm)	Linearity	Resolution	
CD33-30□□	Cable	IEC Class 2 FDA CLASS II	30±4	±0.1% F.S.	4μm	
CD33-30C□□	Connector					2μm
CD33-50□□	Cable		50±10			8μm
CD33-50C□□	Connector					5μm
CD33-85□□	Cable		85±20			15μm
CD33-85C□□	Connector					10μm
CD33-120□□	Cable		120±60			45μm
CD33-120C□□	Connector					30μm

※ Product code : CD33-■□□NV (N=NPN, V=Voltage Output 0-10V), CD33-■□□PV (P=PNP, V=Voltage Output 0-10V),  
CD33-■□□CNV (N=NPN, V=Voltage Output 0-10V), CD33-■□□CPV (P=PNP, V=Voltage Output 0-10V),  
CD33-■□□NA (N=NPN, A=Current Output 4-20mA), CD33-■□□PA (P=PNP, A=Current Output 4-20mA)  
CD33-■□□CNA (N=NPN, A=Current Output 4-20mA), CD33-■□□CPA (P=PNP, A=Current Output 4-20mA)

## 37 page CD3 series

Model	Type	Light source	Measuring range (mm)	Linearity	Resolution ※1
CD3-30□	Cable	Class 2 Laser, 650nm, Max 1mW	30±4	±1% F.S.	4μm
CD3-30C□	Connector				
CD3-50□	Cable		50±10	±1% F.S.	10μm
CD3-50C□	Connector				
CD3-80□	Cable		80±15	±1% F.S.	10μm
CD3-80C□	Connector				
CD3-100□	Cable		100±40	±1% F.S.	30μm
CD3-100C□	Connector				
CD3-250□	Cable		250±150	±1.5% F.S. (up to 250mm) ±2.5% F.S. (up to 400mm)	150μm
CD3-250C□	Connector				

※ Product code : CD3-■□□N (N=NPN), CD3-■□□CN (N=NPN), CD3-■□□P (P=PNP), CD3-■□□CP (P=PNP)  
※1. Unit : Micron. Under AUTO sensitivity. White ceramic as an object

## 40 page CD1 series

Model	Type	Light source	Measuring range (mm)	Linearity	Resolution ※1
CD1-30□	Cable	Class 2 Laser, 650nm, Max 3.3mW	30±4	±2% F.S.	1 3 10
CD1-30C□	Connector				
CD1-50□	Cable		50±10	±1% F.S.	3 10 30
CD1-50C□	Connector				
CD1-100□	Cable		100±35	±2% F.S.	15 50 150
CD1-100C□	Connector				
CD1-130□	Cable		130±50	±3.5% F.S.	20 70 200
CD1-130C□	Connector				
CD1-250□	Cable		250±150	±5% F.S.	150 500 1500
CD1-250C□	Connector				

※ Product code : CD1-■□□N (N=NPN), CD1-■□□CN (N=NPN), CD1-■□□P (P=PNP), CD1-■□□CP (P=PNP)  
※1. Unit : Micron. Under AUTO sensitivity. White ceramic as an object

# CD5 series

World's longest sensing distance of 2 meter with fine linearity of  $\pm 0.1\%$  F.S.



- Best-in-class resolution ( $0.02\mu\text{m}$ ) of CD5L-25
- Best-in-class linearity ( $0.05\%$  F.S.) of CD5-85
- Multiple calculations, one controller supports 3 heads simultaneously.
- Sensing heads can function without controller (Patent pending). Direct connection to PC is possible via RS-422.

## SENSORHEAD VARIATION

Regular type **CD5-30** (Narrow spot)  
**CD5-W30** (Wide spot)

**Short distance**  
5 times better resolution than conventional model  
Measurement range :  $30 \pm 5\text{mm}$   
Resolution :  $0.2\mu\text{m}$   
Linearity :  $\pm 0.08\%$  F.S.

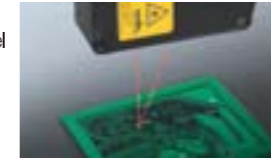

Regular type **CD5-85** (Narrow spot)  
**CD5-W85** (Wide spot)

**Middle distance**  
Highest level of linearity in this class  
Measurement range :  $85 \pm 20\text{mm}$   
Resolution :  $1\mu\text{m}$   
Linearity :  $\pm 0.05\%$  F.S.



Regular type **CD5-W350** (Wide spot)

**Long distance**  
High accuracy & stability by wide spot  
Measurement range :  $350 \pm 100\text{mm}$   
Resolution :  $5\mu\text{m}$   
Linearity :  $\pm 0.08\%$  F.S.



Regular type **CD5-W500** (Wide spot)

**Super long distance**  
Highest level of accuracy for this range  
Measurement range :  $500 \pm 200\text{mm}$   
Resolution :  $10\mu\text{m}$   
Linearity :  $\pm 0.08\%$  F.S.



Regular type **CD5-W2000** (Wide spot)

**Ultra long distance**  
This longest range in the industry  
Measurement range :  $2000 \pm 500\text{mm}$   
Resolution :  $30\mu\text{m}$   
Linearity :  $\pm 0.1\%$  F.S.

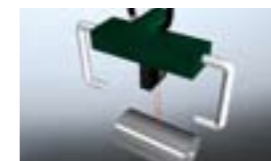

Specular type **CD5-L25** (Narrow spot)  
**CD5-LW25** (Wide spot)

**For transparent and specular objects**  
Measurement of glass thickness is available  
Measurement range :  $25 \pm 1\text{mm}$   
Resolution :  $0.02\mu\text{m}$   
Linearity :  $\pm 0.08\%$  F.S.



# CD5 SENSOR HEADS

## The CD5 series uses OPTEX FA's original design cutting edge technology to achieve high accuracy measurement

### Digital sub-pixel processing Accurate profile reproduction

The linearity has been improved to more than twice that of a conventional product by digital sub-pixel processing. This divides one pixel into 65536 sub-pixels.

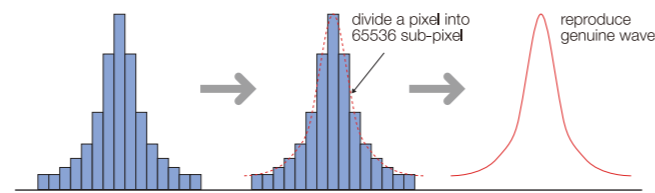

### High resolution electronic shutter Automatic level correction

A high resolution electronic shutter that can be controlled to 1/485th of the sampling period helps to insure stable peak level detection even when unstable surface conditions exist.

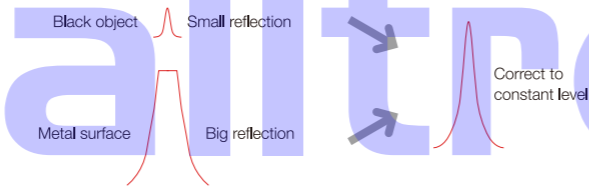

### For uneven and varied luster object Original algorithm

Even if the object is translucent or its surface is uneven, it can detect the position of the true peak thanks to the original Optex designed algorithm.

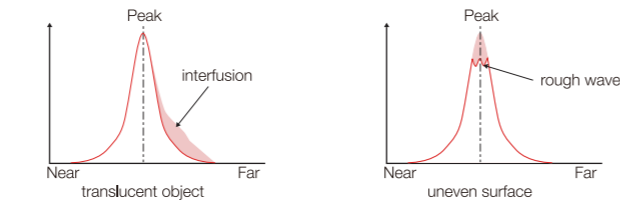

### Standalone operation - no controller required Reliable glass thickness measurement

The Specular type CD5-L25/CD5-LW25 can detect both the surface of glass and measure the thickness without being connected to the controller.

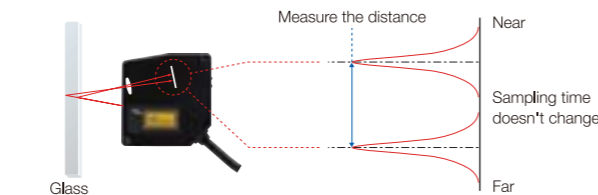

### High accuracy, high speed, high sensitivity High sensitivity linear image sensor

The CD5 series offers 5 times higher accuracy and 10 times higher speed than a conventional product.

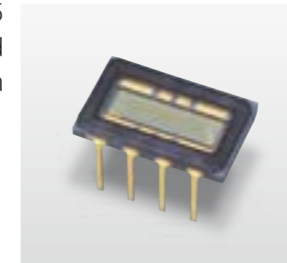

### Low aberration lens "Multi-CLD" lens

Newly developed lens used in the receiver projects a clear image on the image sensor with very little aberration.



Multi-CLD: Multi Combined Low Dispersion

### High speed and high accuracy High speed processing unit

The newly developed processing unit is able to process the measurement data at high speed. It is also able to correct for any distortion and accurately compensates for variations in the readings.



### Highly stable linearity Wide spot type

The wide spot type can measure rough surfaces with a high degree of linearity and stability.

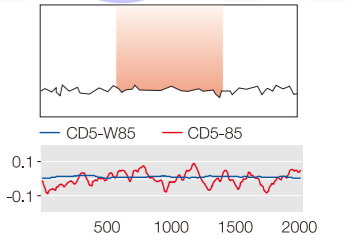

### Cross-talk prevention Preventing cross-talk (world's first)

The newly developed cross-talk prevention function eliminates interference between sensors even when the beams are crossing or are mounted close together.



Sampling period will be 6 times longer

### Water resistance IP67

The CD5 series has an IP67 rating not only at the sensor body but also on the extension cable connector. Additional countermeasures to protect the cable from water are not required.



Note: The sampling period will be 6 times longer. Water droplets on the optical part may cause faulty readings and problems with the measurement.

- CD5
- CD4
- CD33
- CD3
- CD1

- CD5
- CD4
- CD33
- CD3
- CD1

# CD5 CONTROLLERS

Multiple interface for PC, PLC, etc.



Teléfonos: 628-0810 / 628-0811  
 Fax: 4627136  
 Nextel: 832\*8591 / 832\*7745  
 WEB: [www.alltronicsperu.com](http://www.alltronicsperu.com)  
 Calle Manco Capac 125 Ofic. 102 Magdalena del Mar Lima - Perú

CD5

CD4

CD33

CD3

CD1

CD5

CD4

CD33

CD3

CD1

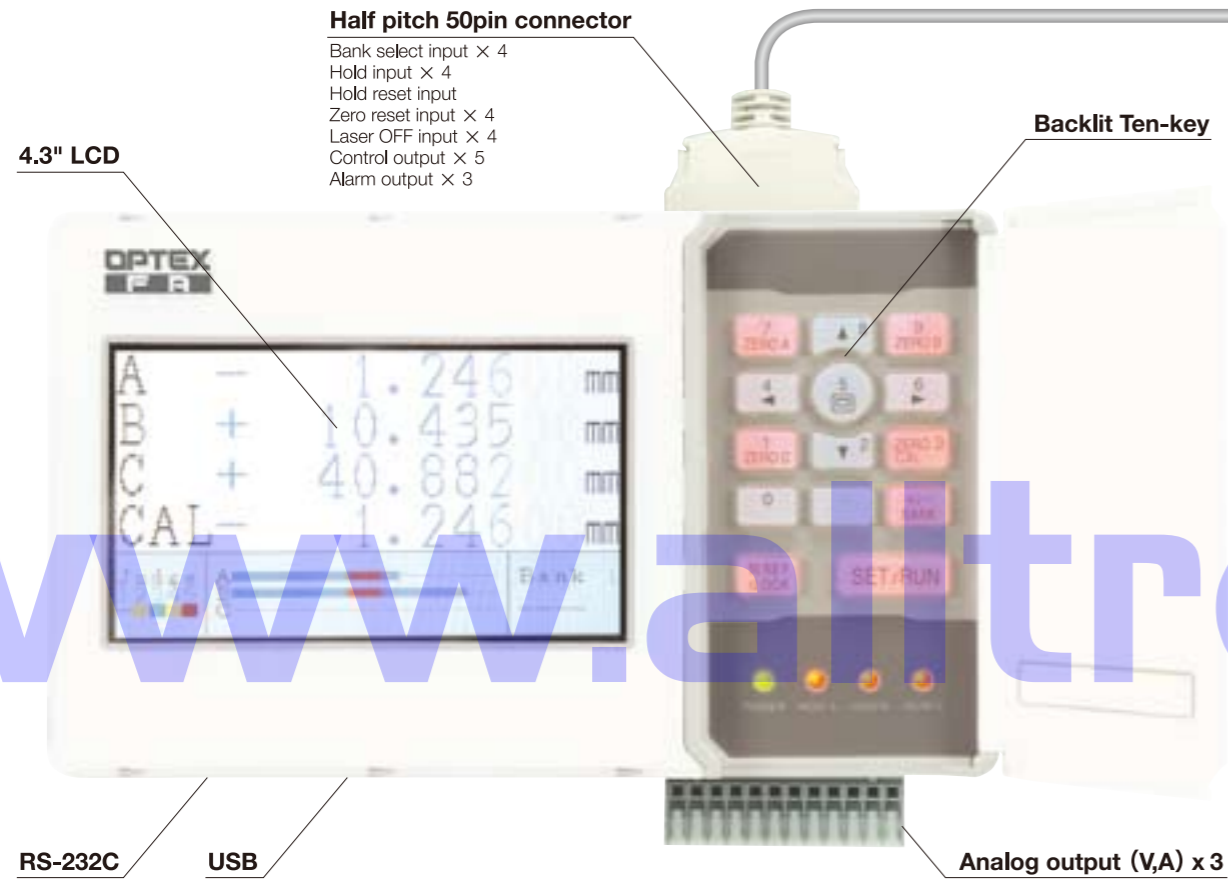

## Multiple SETUP is available 16 Banks for SETUP

You can setup 16 sets of measurement parameter for 16 application. Bank is changed by Ten-key, external inputs and RS-232C communication.

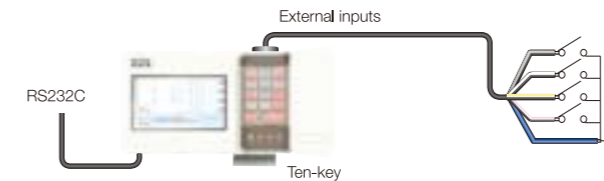

## Effective for sorting 5 Outputs have individual threshold

5 Outputs that have individual threshold, upper and lower limit, is available. This is effective for sorting application.

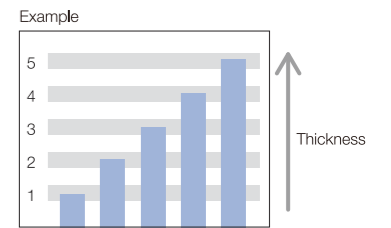

## Wave monitoring without PC or external monitor Wave monitoring function

You can monitor the wave form and verify if the sensor head and object position are correct by using the wave monitoring function.

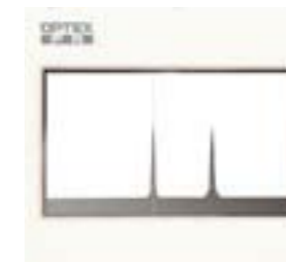

## Easy SETUP Backlit Ten-key

Backlit Ten-key display panel shows which keys are active.



## Multi measurement with one controller 3 heads multi calculation (world's first)

Up to three sensor heads can be connected to one controller unit. Calculation with result from three heads is available that can be used to solve various applications

- Levelness
- Contortion
- Warpage
- Level difference
- Thickness
- Shifting



## Easy SETUP Backlit Ten-key and display guide

Setup of basic sensor parameter and calibration are easily done by Backlit ten-key and display. Backlit ten-key panel shows which keys are active.



## From remote place Up to 50m

Controller can be located up to a maximum distance of 50m from the sensor head. By interconnecting the cable DSL-1212-G05M.



## Controllable from PC remotely USB and RS-232C

Controller has USB and RS-232C port so that you can control sensor heads effectively and flexibly.



# SYSTEM PART NUMBERS

## Sensorhead

**CD5-30** Short range : 30 ±5mm  
**CD5-W30**

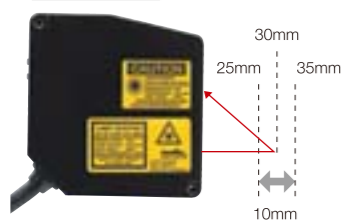

**CD5-L25** Specular type : 25 ±1mm  
**CD5-LW25**



**CD5-85** Middle range : 85 ±20mm  
**CD5-W85**

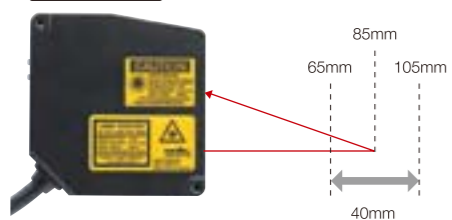

**CD5-W350** Long range : 350 ±100mm

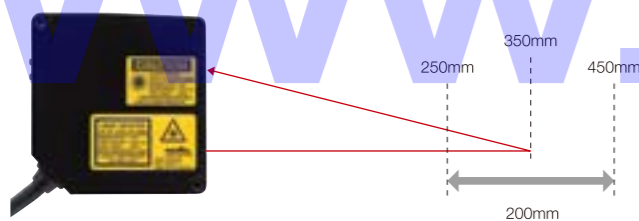

**CD5-W500** Super long range : 500 ±200mm

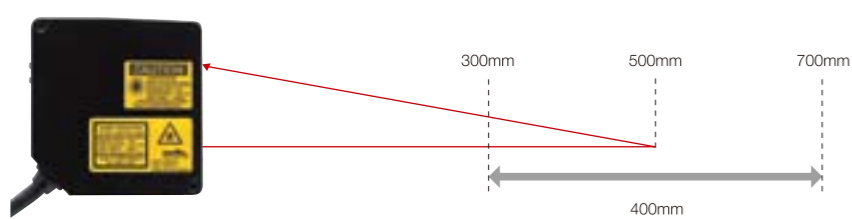

**CD5-W2000** Ultra long range : 2000 ±500mm

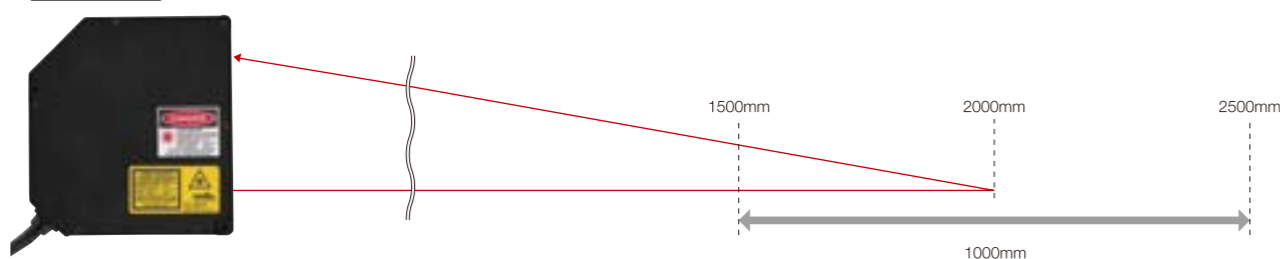

## Controller



**Model No. : CD5A-N (NPN), CD5A-P (PNP)**  
Type : CD5 controller  
Description : Controller unit for CD5 system with 4.3" TFT LCD and Backlit Ten-key  
Interface : Analog output NPN input/output, RS-232C, USB

## Option

### Cable for sensor head and controller

- DSL1212-G02M** : 2m  
Cable for sensor head to connect controller that can be connected in serial up to 50m
- DSL1212-G05M** : 5m  
Cable for sensor head to connect controller that can be connected in serial up to 50m

### Cable for sensor head

- DOL1212-G05M** : 5m  
Cable for sensor head when use without controller

### I/O Connector cable

- IO-EXP-AOD5** : 3m  
IEEE1284 half pitch 50pin

### Sensor navigator

- CD5-SFT** : Free Software for PC

## System configuration example

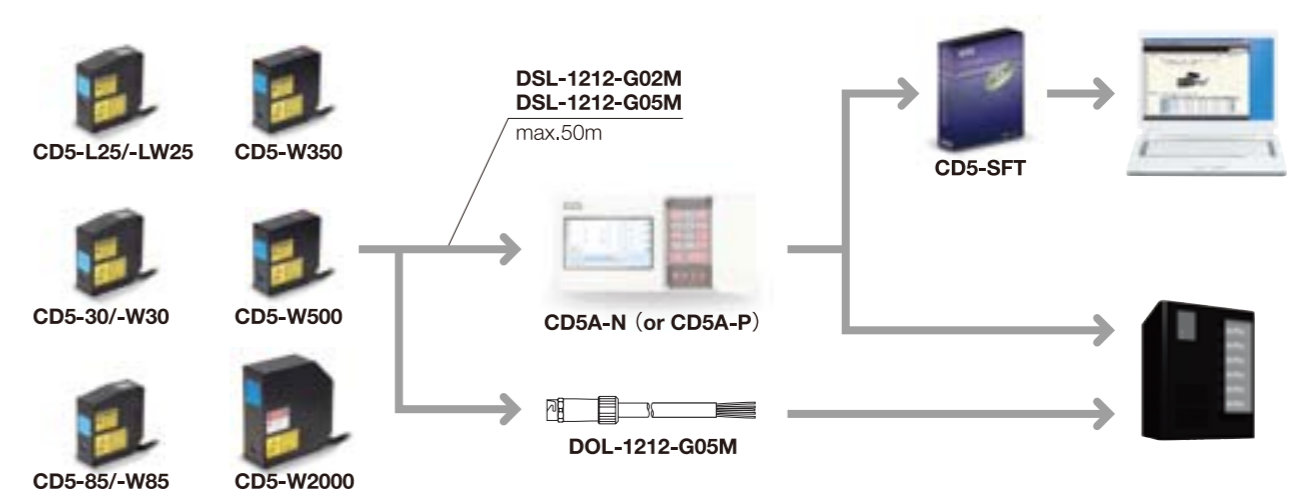

# DIMENSIONS

## Sensor head

Model No. : CD5-L25/-LW25

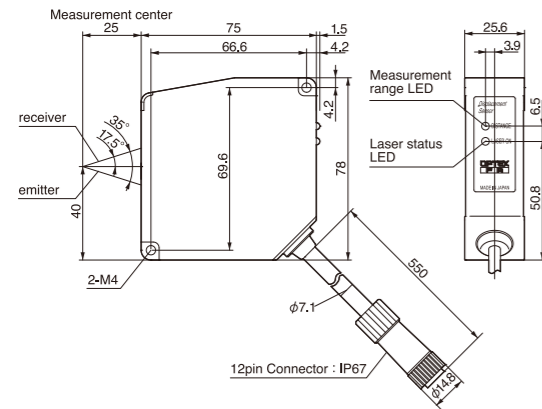

Model No. : CD5-30/-W30

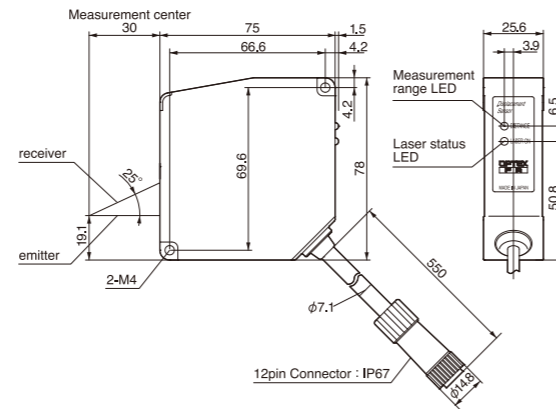

Model No. : CD5-85/-W85

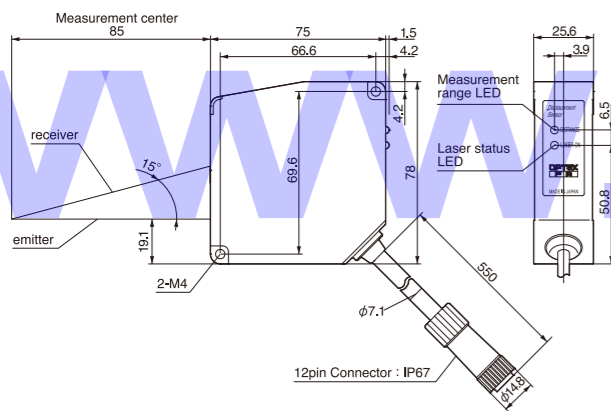

Model No. : CD5-W350

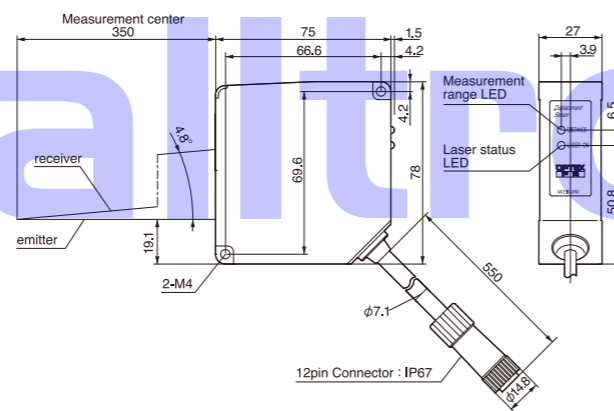

Model No. : CD5-W500

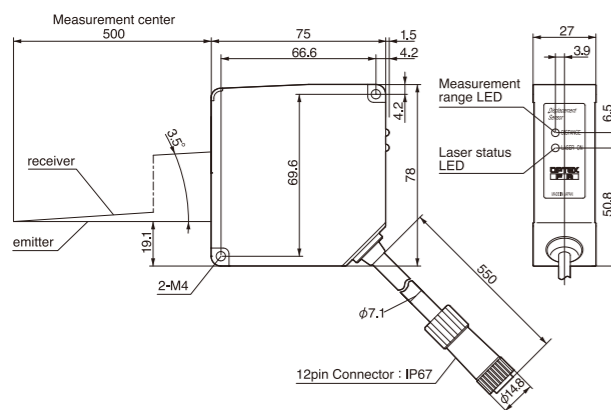

Model No. : CD5-W2000

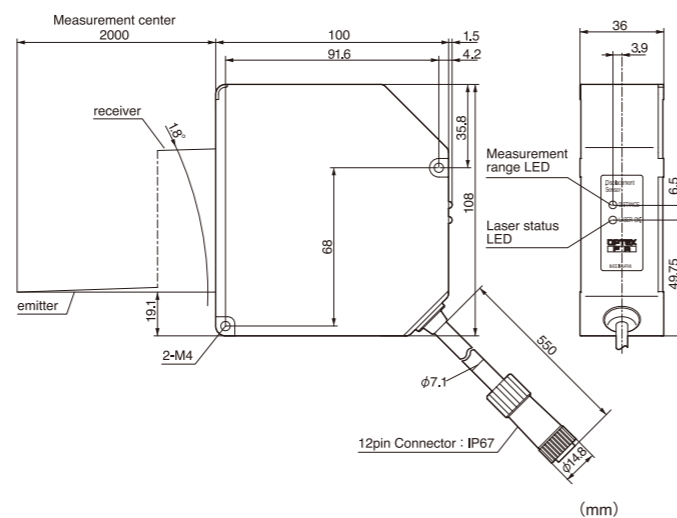

## Controller

Model No. : CD5A-N(-P) common in NPN and PNP types

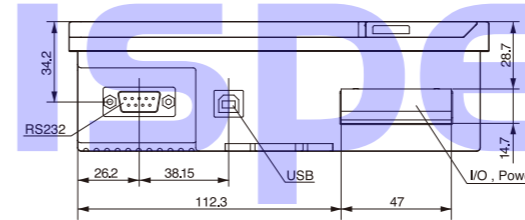
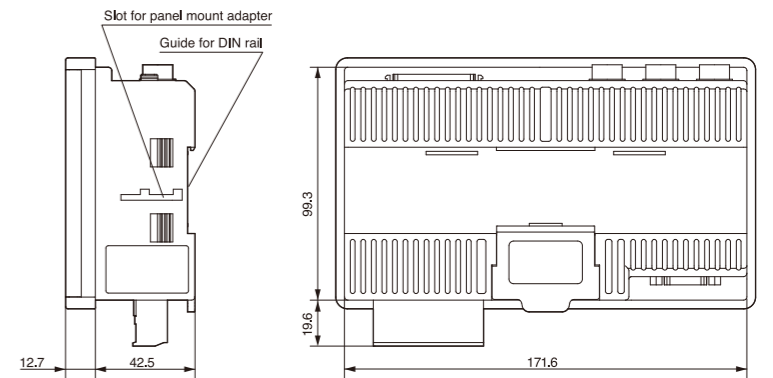
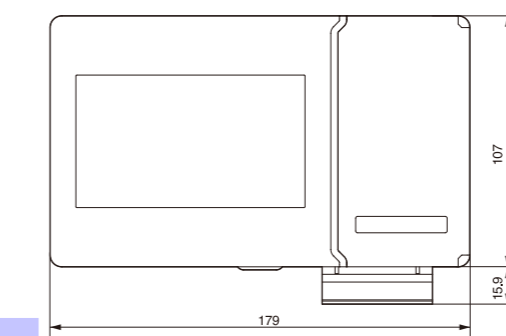
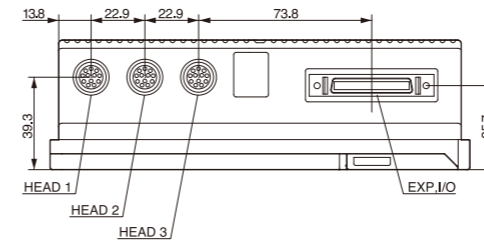

(mm)

## Cable

Model No. : DSL-1212-G02M

: Extension cable between amplifier and sensor head.

Model No. : DOL-1212-G05M

: Sensor head cable 5m

Model No. : DSL-1212-G05M

: Extension cable between amplifier and sensor head.

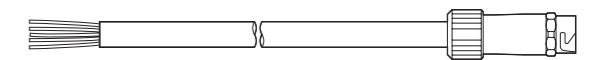
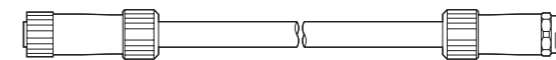

Model No. : IO-EXP-AOD5

: I/O connector cable 3m

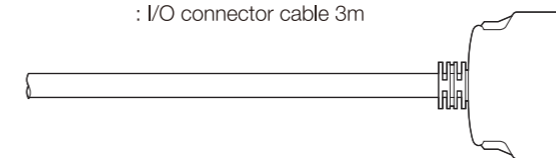

# SPECIFICATIONS

## Sensor head

Model	CD5-L25	CD5-LW25	CD5-30	CD5-W30
<b>Optical method</b>	Specular reflection		Diffuse reflection	
<b>Measurement dist.</b>	25mm		30mm	
<b>Measurement range</b>	±1mm		±5mm	
<b>Light source</b>	Red laser diode Wavelength 650nm / Maximum output 390μW		Wavelength 650nm / Maximum output 1mW	Wavelength 658nm / Maximum output 1mW
<b>Laser class</b>	<b>IEC/JIS</b> Class 1	<b>FDA</b> CLASSII		Class 2
<b>Spot size (*1)</b>	Appx.25×35μm	Appx.100×700μm	Appx.30×100μm	Appx.260×1,000μm
<b>Light receiving element</b>	Linear image sensor			
<b>Linearity</b>	±0.08% F.S.			
<b>Resolution (*2)</b>	0.02μm		0.2μm	
<b>Sampling period (*3)</b>	100/200/400/800/1600/3200μm Setup to be done through the controller (CD5A series)			
<b>Temperature drift (*4)</b>	±0.01% F.S. / °C	±0.05% F.S. / °C	±0.01% F.S. / °C	
<b>Serial I/F</b>	RS-422 9.6k to 1843.2kbps			
<b>Supply voltage</b>	DC12~24V ±10% or from controller (CD5A series)			
<b>Indicator</b>	Laser emission indicator : Green (ON during laser emission) Distance indicator : Orange (Lights around center) Distance indicator : Green (Lights at the far side) Distance indicator : Red (Lights at the near side) Distance indicator : Alternative Red/ Green(Out of range)			
<b>Protection category</b>	IP67 (Including connecting part)			
<b>Operating temp / humidity</b>	-10 to +50°C (No condensation) / 35% to 85%RH			
<b>Storage temp / humidity</b>	-20 to +60°C (No condensation) / 35% to 85%RH			
<b>Ambient illuminance</b>	Max. 3,000lx (Surface illuminance, incandescent lamp)			
<b>Vibration resistance</b>	10 to 55Hz Double amplitude 1.5mm 2 h per XYZ axes			
<b>Shock resistance</b>	50G (500m/s <sup>2</sup> ) X,Y,Z 3times			
<b>Cable extension</b>	Up to 50 m using an optional extension cable (unbundled)			
<b>Material</b>	Sensor head housing : Diecast aluminum cover of emitting/receiving part : Glass			
<b>Weight</b>	Appx. 250 g (Including cable)			

(Measurement condition)  
Unless otherwise designated, measurement condition is as follows. Using special controller / operating temperature, 23°C (ordinary temperature) / supply voltage, 24 V DC / sampling period : 100μs (CD5-W350 / -W500 / -W2000 : 800μs) 256 times in average/ center/ standard testing object (specular reflection: evaporated aluminum mirror, diffuse reflection: white ceramic) / digital measured value.

\*1 Defined with center strength 1/e<sup>2</sup> (13.5%) at the center. There may be leak light other than the specified spot size. The sensor may be affected when there is a highly reflective object close to the detection area.

\*2 4096 times in average. Other conditions are same as the above condition.

\*3 Default setting of sampling period is as follows.

CD5-□□25~□85 :100μs

CD5-W350~W2000 :800μs

\*4 The typical value in the above condition.

## Sensor head

Model	CD5-85	CD5-W85	CD5-W350	CD5-W500	CD5-W2000
<b>Optical method</b>	Diffuse reflection				
<b>Measurement dist.</b>	85mm		350mm	500mm	2000mm
<b>Measurement range</b>	±20mm		±100mm	±200mm	±500mm
<b>Light source</b>	Red Laser Diode Wavelength 650nm / Maximum output 1mW				
<b>Laser class</b>	<b>IEC/JIS</b> Class 2	<b>FDA</b> CLASSII			Class 3R
<b>Spot size (*1)</b>	Appx.70×290μm	Appx.260×1200μm	Appx.700×2,400μm	Appx.1,000×3,700μm	Appx.2,100×7,800μm
<b>Light receiving element</b>	Linear image sensor				
<b>Linearity</b>	±0.05% F.S.		±0.08% F.S.	±0.08% F.S.	±0.1% F.S.
<b>Resolution (*2)</b>	1μm		5μm	10μm	30μm
<b>Sampling period (*3)</b>	100/200/400/800/1600/3200μm Setup to be done through the controller (CD5A series)				
<b>Temperature drift (*4)</b>	±0.01% F.S. / °C				±0.05% F.S. / °C
<b>Serial I/F</b>	RS-422 9.6k to 843.2kbps				
<b>Supply voltage</b>	DC12~24V ±10% or from controller (CD5A series)				
<b>Indicator</b>	Laser emission indicator : Green (ON during laser emission) Distance indicator : Orange (Lights around center) Distance indicator : Green (Lights at the far side) Distance indicator : Red (Lights at the near side) Distance indicator : Alternative Red/ Green(Out of range)				
<b>Protection category</b>	IP67 (Including connecting part)				
<b>Operating temp / humidity</b>	-10 to +50°C (No condensation) / 35% to 85%RH				
<b>Storage temp / humidity</b>	-20 to +60°C (No condensation) / 35% to 85%RH				
<b>Ambient illuminance</b>	Max. 3,000lx (Surface illuminance, Incandescent lamp)				
<b>Vibration resistance</b>	10 to 55Hz Double amplitude 1.5mm 2 h per XYZ axes				
<b>Shock resistance</b>	50G (500m/s <sup>2</sup> ) X,Y,Z 3times				
<b>Cable extension</b>	Up to 50 m using an optional extension cable (unbundled)				
<b>Material</b>	Sensor head housing : Diecast aluminum cover of emitting/receiving part : Glass				
<b>Weight</b>	Appx. 250 g (Including cable)				Appx. 450 g (Including cable)

## Controller

Model	CD5A-N (NPN input/output type)	CD5A-P (PNP input/output type)
<b>Number of heads</b>	Max. 3pcs	
<b>Supply voltage</b>	12 to 24V, DC ±10%	
<b>Power consumption</b>	350mA / 24V (When connected with 3 sensor heads. Including analog current output)	
<b>Temp drift</b>	±0.01% F.S./°C	
<b>Interface</b>	RS232 / USB	
<b>Analog output</b>	Voltage output ± 10V/F.S. (Output impedance 100Ω) Current output 4 to 20mA/F.S. (Load impedance max.300Ω)	
<b>Alarm output</b>	NPN open collector	PNP open collector
	Max. 100mA / 24V DC (residual voltage max. 1.8V) Turns ON when the sensor head fails in measurement.	
<b>Control output</b>	NPN open collector	PNP open collector
	Max. 100mA / 24V DC (residual voltage max. 1.8V) HI/LO setting for each line and hysteresis setting are available.	
<b>Bank select input</b>	Turns ON when connected to GND	Turns ON when connected to 12 to 24V
	16 banks selectable	
<b>Hold input</b>	Turns ON when connected to GND	Turns ON when connected to 12 to 24V
	Measurement value holding (selectable in the menu)	
<b>Zero reset input</b>	Turns ON when connected to GND	Turns ON when connected to 12 to 24V
	Zero reset of Head A measurement value / Head B measurement value / Head C measurement value / Calculation value is available.	
<b>Laser off input</b>	Turns ON when connected to GND	Turns ON when connected to 12 to 24V
	Laser shutoff of Head A / Head B / Head C is available.	
<b>Optional features</b>	Calculation setting (calculation formula, measurement value increase/decrease direction, value of K, shift), hold settings, filter setting (filter, cut-off frequency), memory bank setting, RS232 setting, memory copying function, measurement value display digit number setting, display brightness setting, key illumination setting	
<b>Display</b>	4.3" TFT LCD	
<b>Protection category</b>	IP20	
<b>Operating temp / humidity</b>	-10 to +50°C (No condensation) / 35 to 85% RH	
<b>Storage temp / humidity</b>	-20 to +60°C (No condensation) / 35 to 85% RH	
<b>Vibration resistance</b>	10 to 55Hz, Double amplitude 1.5mm, 2h for XYZ axes	
<b>Shock resistance</b>	20G(196m/s <sup>2</sup> ), 3 times for XYZ axes	
<b>Material</b>	Chassis: Polycarbonate, connection terminals : Nylon 66	
<b>Weight</b>	Approx. 550 g (Including connection terminals)	



# LINEARITY (Typical example data)

Model No. : CD5-L25

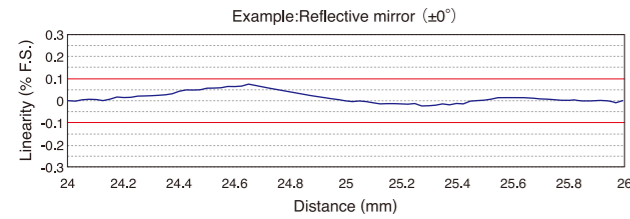

Model No. : CD5-LW25

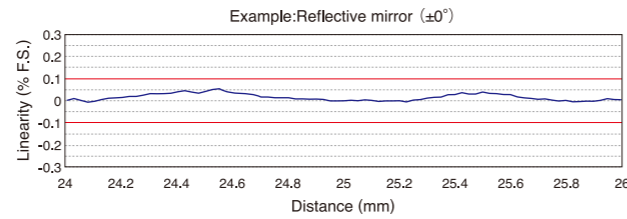

Model No. : CD5-30

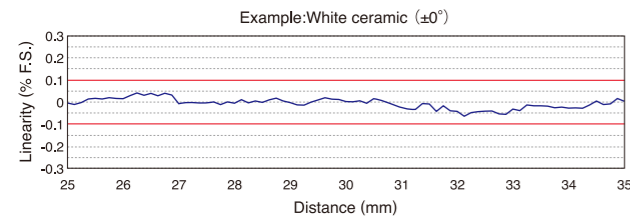

Model No. : CD5-W30



Model No. : CD5-85

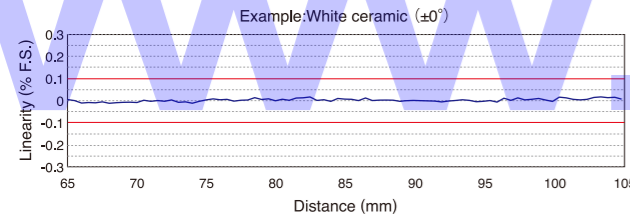

Model No. : CD5-W85

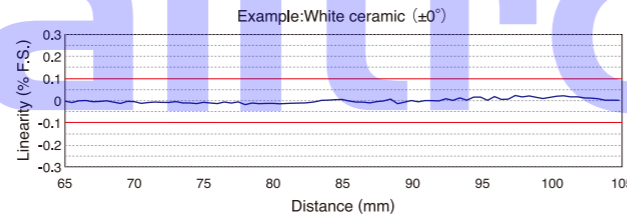

Model No. : CD5-W350

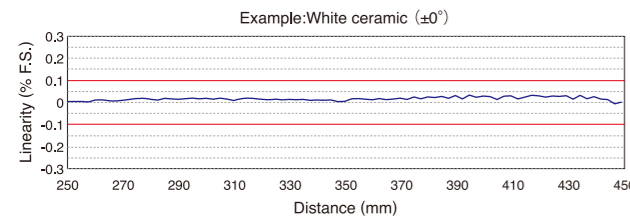

Model No. : CD5-W500

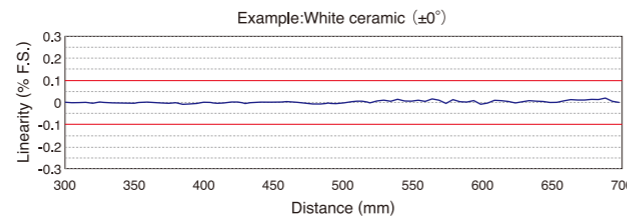

Model No. : CD5-W2000

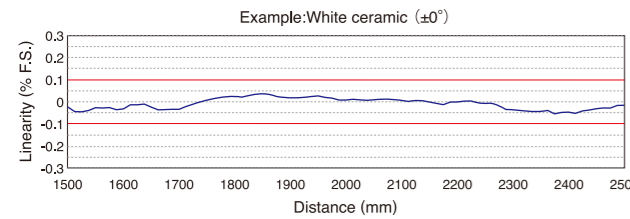

# SPOT SIZE

Model No. : CD5-L25

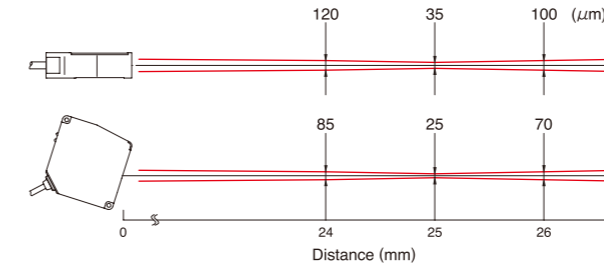

Model No. : CD5-LW25

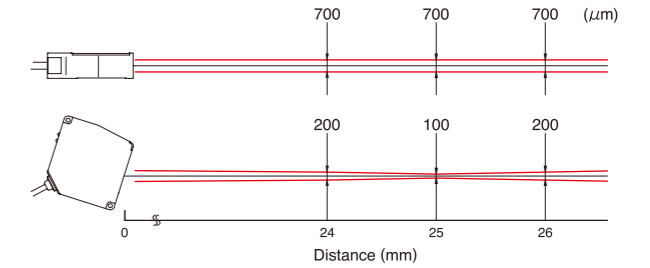

Model No. : CD5-30

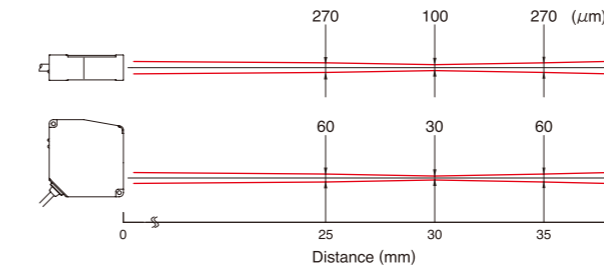

Model No. : CD5-W30

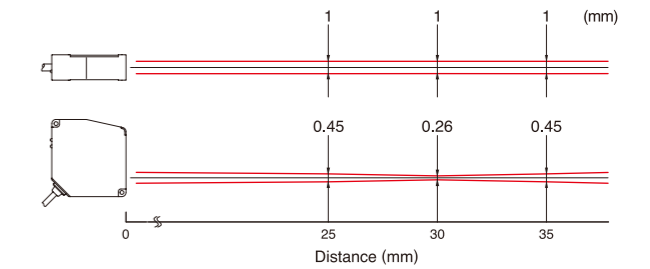

Model No. : CD5-85

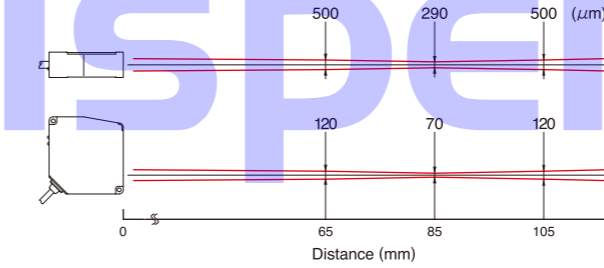

Model No. : CD5-W85

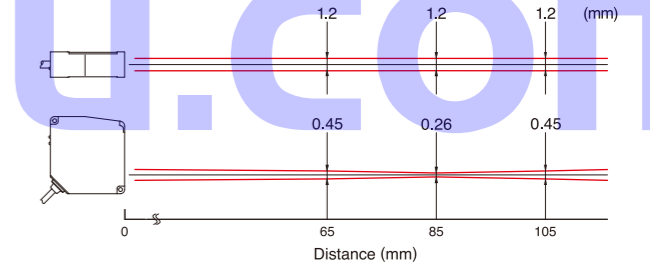

Model No. : CD5-W350

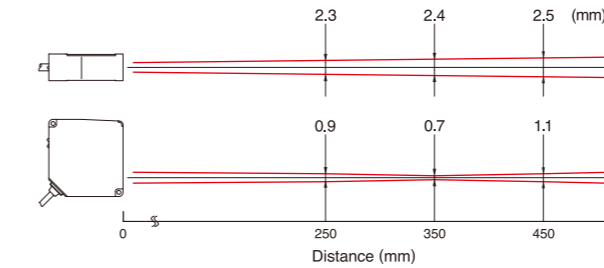

Model No. : CD5-W500

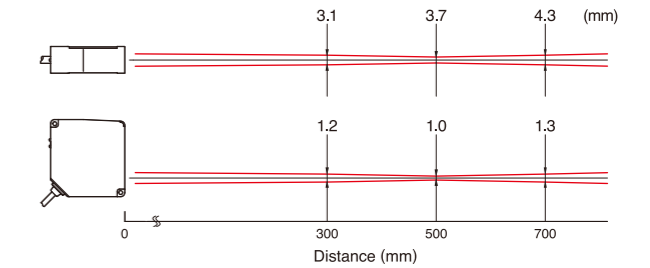

Model No. : CD5-W2000

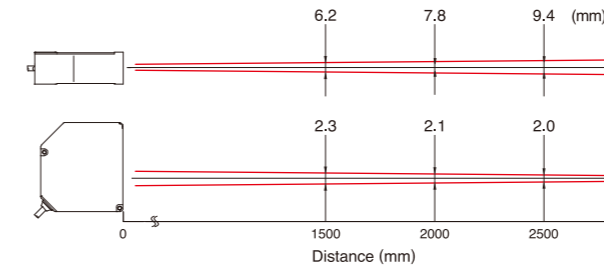

www.alltronicsperu.com

# INTERFERENCE AREA

CD5

CD4

CD33

CD3

CD1

Model No. : CD5-L25

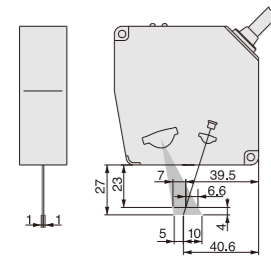

Model No. : CD5-30

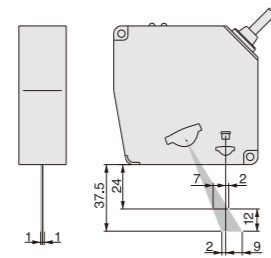

Model No. : CD5-85

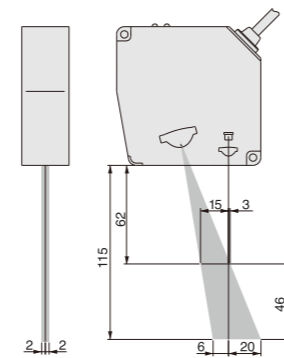

Model No. : CD5-LW25

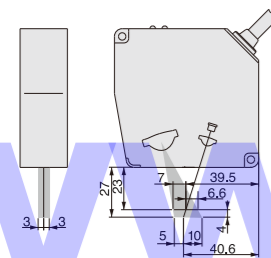

Model No. : CD5-W30

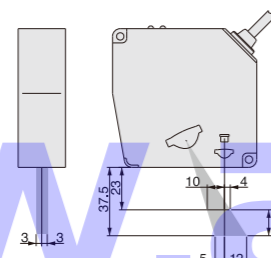

Model No. : CD5-W85

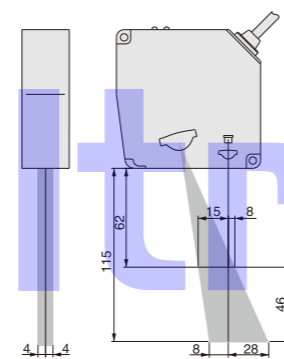

Model No. : CD5-W350

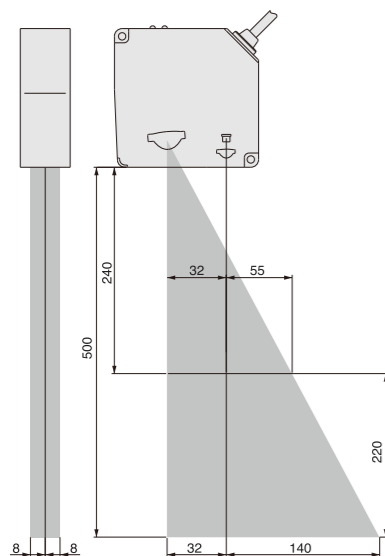

Model No. : CD5-W500

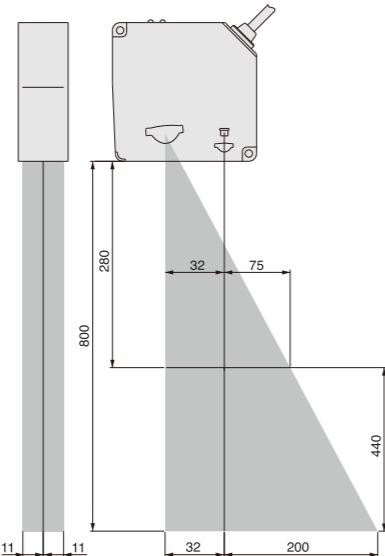

Model No. : CD5-W2000

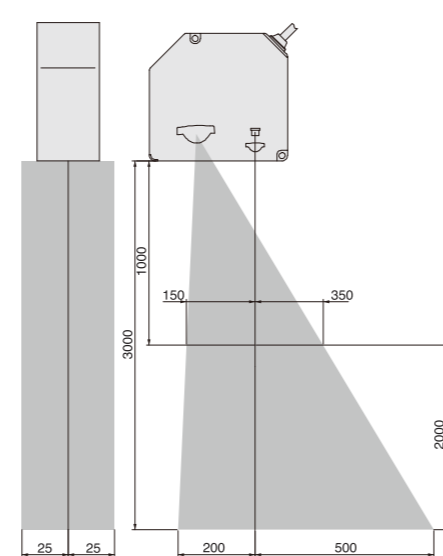

(mm)

# INPUT / OUTPUT DIAGRAMS

CD5

CD4

CD33

CD3

CD1

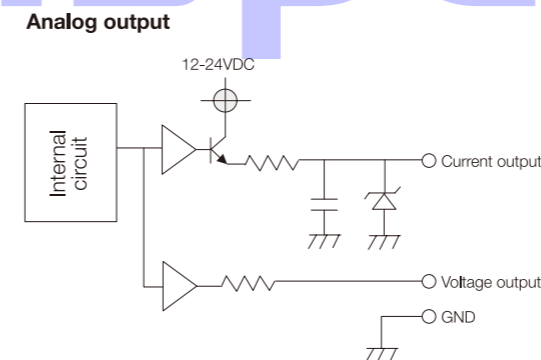
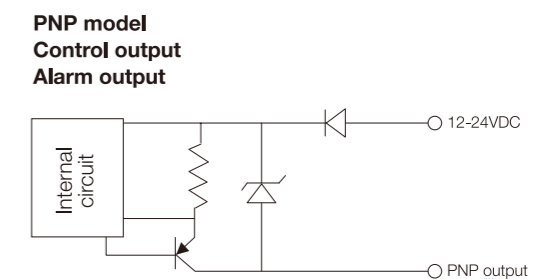
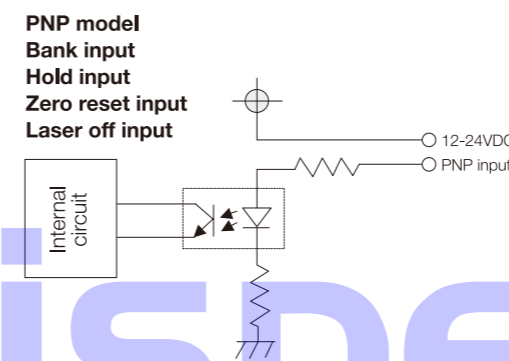
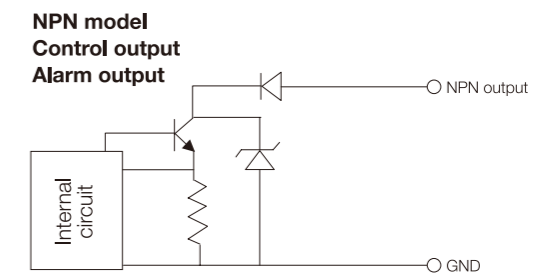
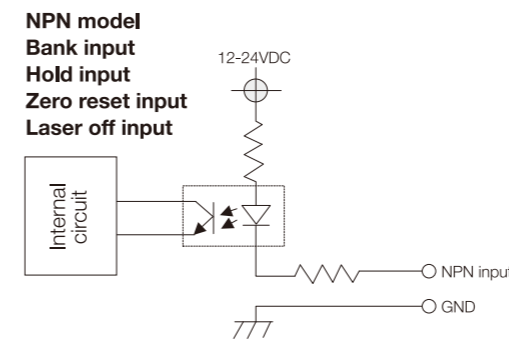

# CD4 series

CD4 Series with linear image sensor and electronic shutter provides accurate measurement.

- Laser displacement sensor features easy setup and operation.
- High accuracy of  $0.1\ \mu\text{m}$  resolution and  $\pm 0.1\%$  F.S. linearity. (Specular Type)
- Specular type (CD4L-25) optics that are ideal for glass sensing.



## SENSORHEAD VARIATION

### <For general use>

Regular type **CD4-30** (IEC Class 2 「FDA CLASS II」 Type)  
**CD4-30-3R** (High power Class 3R Type)

#### Short distance

Tire inspection

Measurement range :  $30 \pm 5\text{mm}$   
 Resolution :  $1\ \mu\text{m}$   
 Linearity :  $\pm 0.1\%$  F.S.



Regular type **CD4-85** (IEC Class 2 「FDA CLASS II」 Type)  
**CD4-85-3R** (High power Class 3R Type)

#### Middle distance

Checking clear package of IC mounted on PCB

Measurement range :  $85 \pm 20\text{mm}$   
 Resolution :  $3\ \mu\text{m}$   
 Linearity :  $\pm 0.1\%$  F.S.



Regular type **CD4-350** (IEC Class 2 「FDA CLASS II」 Type)  
**CD4-350-3R** (High power Class 3R Type)

#### Long distance

Monitoring the die cast

Measurement range :  $350 \pm 100\text{mm}$   
 Resolution :  $40\ \mu\text{m}$   
 Linearity :  $\pm 0.1\%$  F.S.



### <For glass material>

Specular type **CD4L-25** (IEC Class 1 「FDA CLASS II」 Type)

#### Specular type

Monitoring warping sagging of glass plate

Measurement range :  $25 \pm 1\text{mm}$   
 Resolution :  $0.1\ \mu\text{m}$   
 Linearity :  $\pm 0.1\%$  F.S.



# CD4 SENSOR HEADS

## CD4 Series laser displacement sensor with linear image sensor and electronic shutter provides accurate measurement.

### Measuring range

#### <General use>

**CD4-30**  
**CD4-30-3R** Short range : 30 ±5mm

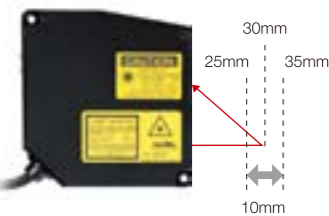

#### <Glass material>

**CD4L-25** Specular type : 25 ±1mm  
 The optical path is designed to project the correct angle for the detection of specular reflections from transparent objects.



**CD4-85**  
**CD4-85-3R** Middle range : 85 ±20mm

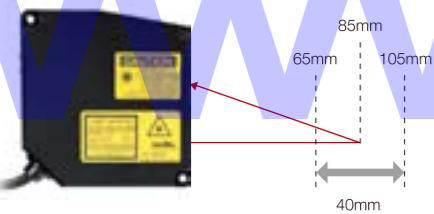

**CD4-350**  
**CD4-350-3R** Long range : 350 ±100mm

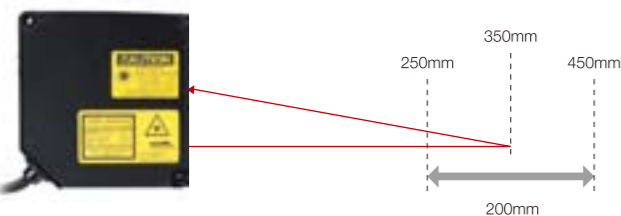

### Class 2 (IEC/JIS) CLASS II (FDA) laser product

**CD4-30** **CD4-85** **CD4-350**

High power type (models with "-3R") has class 3 laser



### High speed sampling rate

The CD4 Displacement sensor has a 100µsec. sampling rate and high density linear image detector.

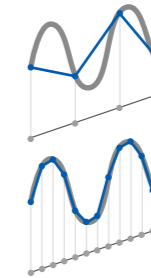

Conventional displacement sensor with slow response.

CD4 Series sensors, high speed sampling rate improves overall accuracy.

### Class 3R - High power types

**CD4-30-3R** **CD4-85-3R** **CD4-350-3R**

For matte black objects or any application that requires a higher power laser, there are models of the CD4 series available which use a Class 3R light source.



### Class 1 (IEC/JIS) CLASS II (FDA) laser product

**CD4L-25**

CD4L-25 is registered to CDRH. (Center of devices and radiological health)



### IP67 Environmental rating

The sensing heads of the CD4 series have an IP67 rating for use in applications where they may be exposed to water.



### Hint of installation for best accuracy

To obtain accuracy the sensor head must be oriented as shown below.

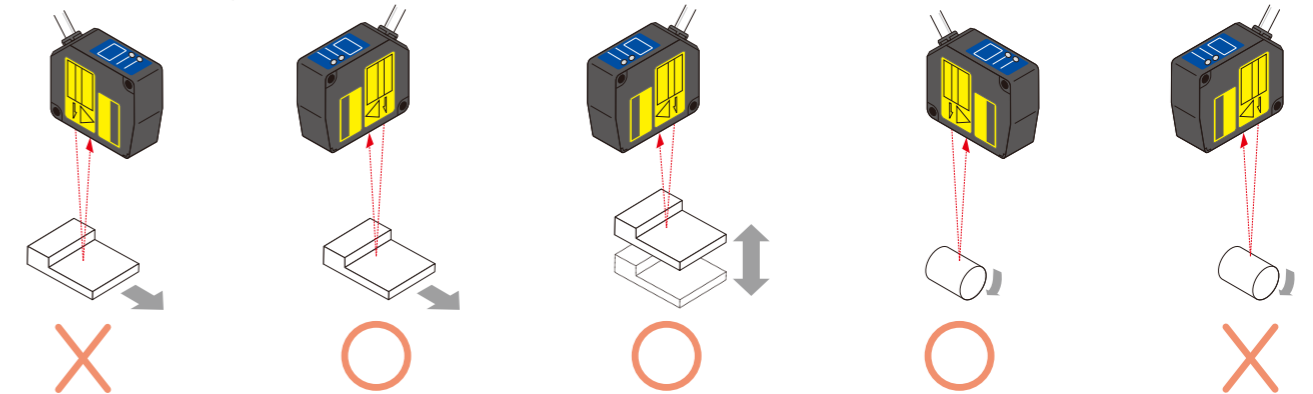

# CD4 CONTROLLERS

The CD4 controller is easy to operate with simple pushbutton setup and an LCD display to verify / change the settings.

## LCD Display

The CD4A-N(or P) controller has a built-in color display that indicates multiple data values on the same screen. Distance values from both heads, calculated value, output status, bank number, etc. are displayed on the normal run screen.



## Light intensity monitor (For CD4L-25 only)

For stable measurement and improved accuracy the light intensity needs to be adjusted to the optimum setting. With the built-in monitor the status of the level can be verified.

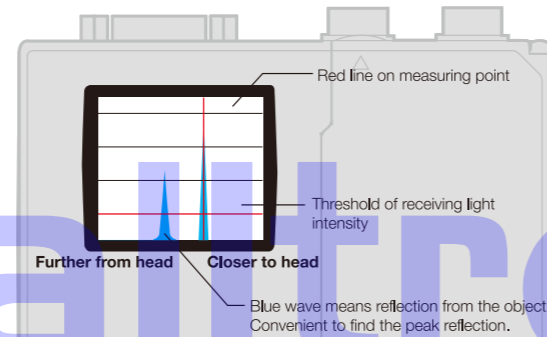

## Ten formulas of calculation

A	Sensor head A
B	Sensor head B
A+B	Adding of A and B
A-B	Gap between A and B
-A-B	Reverse of A+B
K-A-B	K = distance between sensors. Good for measuring thickness.
K+A+B	K = Offset value
K+A-B	K = Offset value
K+A	Offset the sensor A. K = Offset value
K+B	Offset the sensor B. K = Offset value

## 8 Banks selections

Bank No.	Bank 2 input	Bank 1 input	Bank 0 input
0	OFF	OFF	OFF
1	OFF	OFF	ON
2	OFF	ON	OFF
3	OFF	ON	ON
4	ON	OFF	OFF
5	ON	OFF	ON
6	ON	ON	OFF
7	ON	ON	ON

## Electronic shutter

The microcomputer in the CD4 controller will automatically control the shutter speed depending upon the reflectance of the target. This will select the best light intensity level for accurate measurement and will help to minimize the error (AUTO Sensitivity Mode).

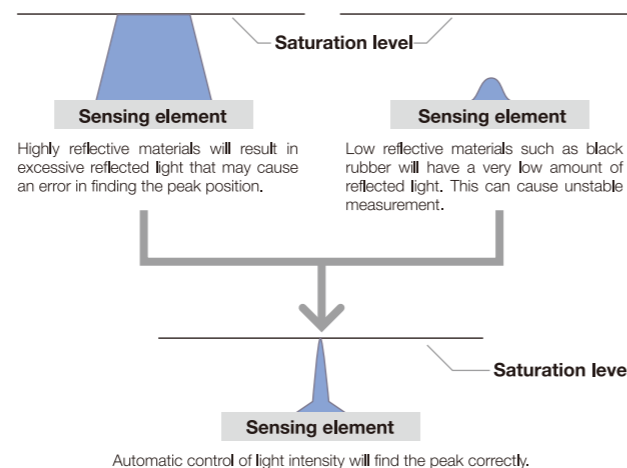

## RS-232C Communications

By connecting the CD4 controller to a PC, the following operations can be performed from the PC via RS232C.

- Writing and reading out the setting value
- Reading out the measurement value
- Reading out the control output status
- Operating the control input
- Data buffer function

Communication method	RS-232C
Transmission type	Asynchronous
Baud rate	9600/19200/38400/115200 bps
Transmission code	ASCII
Data length	7/8 bit
Stop bit length	1 bit
Parity check	Nil/Even number/Odd number
Data classification	STX·ETX

The underlined values are the factory default settings.

Adjust the communication settings of the PC and the CD4 using the values in the above table. The settings of the CD4 controller can be accessed in screen number 14 (RS232C).

## Low / High pass filters

High / Low pass filters are built into the CD4 controller. A low pass filter will help to reduce any sudden changes in the measurement while the high pass filter will eliminate slow gradual changes.



Easy disconnection of QD type.

## 5 Independent outputs are available

This is convenient for sorting items according to size. Each of the 5 comparator outputs can be set independently, all outputs have a high and low threshold limit.

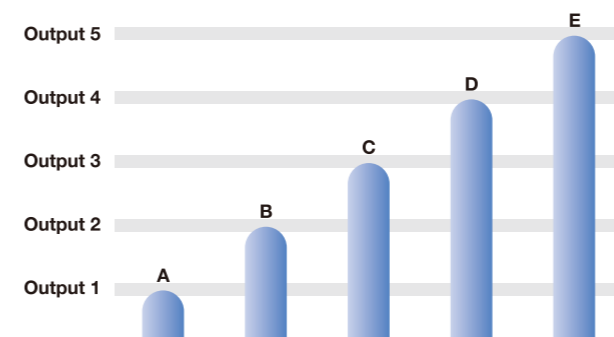

## Two sensing heads can be controlled

Therefore it computes for the purpose of measuring thickness, width, etc. Independent measurement from each head is possible as well. Any combination of measurement heads (30, 85, 350) can be used together.

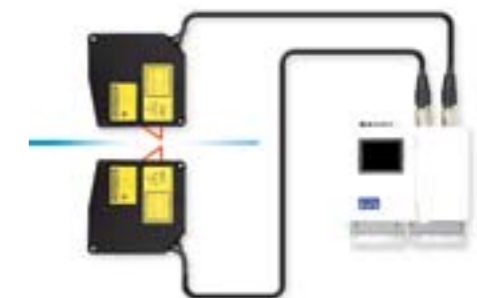

# DIMENSIONS

## CD4 series sensor head

Model No. : CD4-30/-30-3R/-85/-85-3R

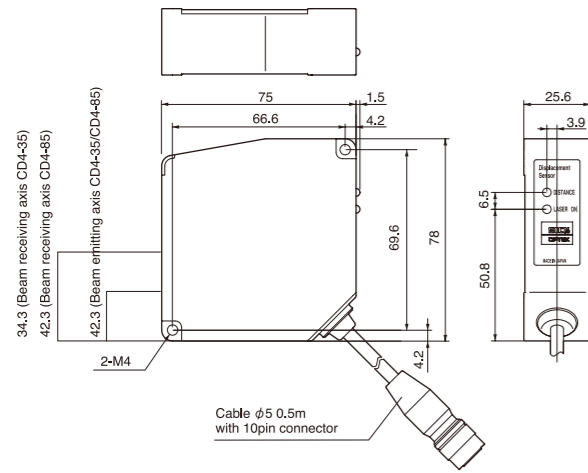

Model No. : CD4-350/-350-3R

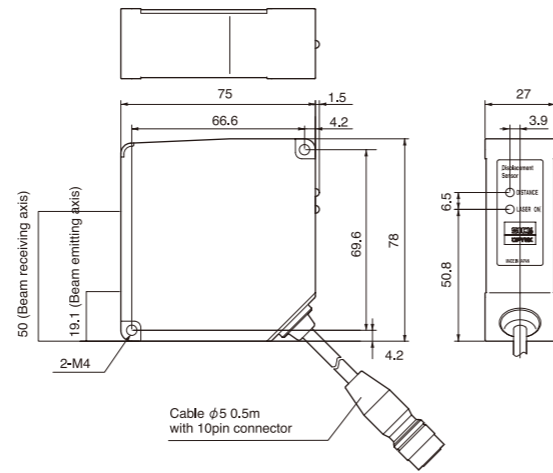

## CD4L-25 Sensor head

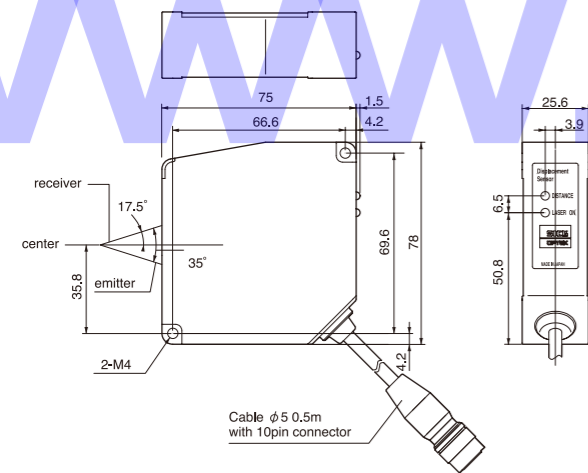

## Cable

- Model No. : CD4CN-S-ROBOT : Extension 2m cable to connect the sensor head
- Model No. : CD4CN-5S-ROBOT : Extension 5m cable to connect the sensor head



## Controller

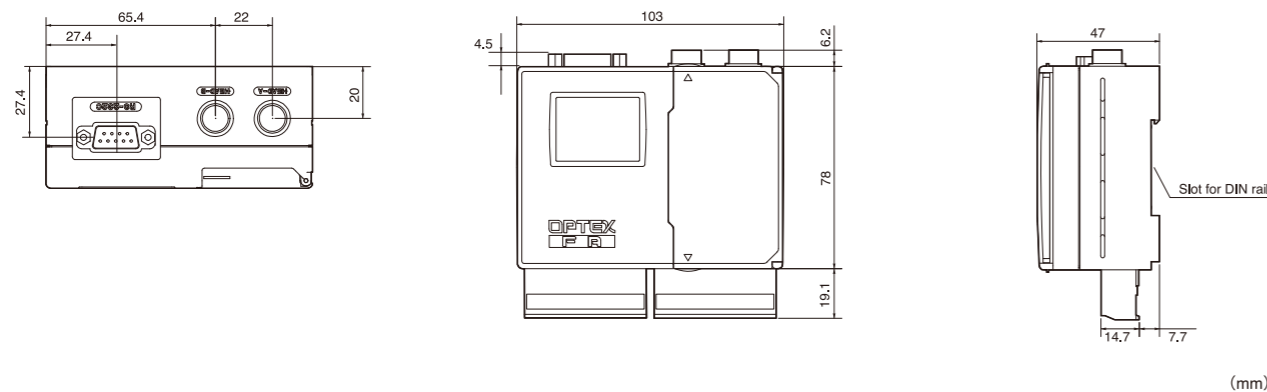

(mm)

# SPECIFICATIONS

## CD4 series

Model	IEC Class 1 (FDA CLASS II) Type	CD4-30	CD4-85	CD4-350
	High power Class 3R Type	CD4-30-3R	CD4-85-3R	CD4-350-3R
<b>Measurement range</b>		30 ±5mm	85 ±20mm	350 ±100mm
<b>Light source</b>	(Regular type)	Class 2 (IEC/JIS) CLASS II (FDA) Red laser diode , 650nm, max 1m W		
	(High power type)	Class 3R (IEC/JIS) CLASS III a (FDA) Red laser diode, 650nm, max 5mW		
<b>Spot size</b> (*1)		30×100μm	70×290μm	300×700μm
<b>Linearity</b> (*2)		±0.1% F.S.		
<b>Resolution</b> (*3)		1μm	3μm	40μm
<b>Supply voltage</b>		Supplied by CD4A-N/P controller		
<b>Temp drift</b>		±0.01% F.S. / °C		
<b>Laser emission indicator</b>		Green = Laser emission		
<b>Measurement indicator</b>		Red = In range, closer than center 5% of measurement range (0 to 45%)		
		Orange = Within +/- 5% of the center of the measuring range		
		Green = In range, farther than center 5% of measurement range (55 to 100%)		
		Red/Green alternating = Out of measuring range		
<b>Protection category</b>		IP67		
<b>Operation temp / humidity</b>		-10 to 45 °C ( 14 to 113 °F) , 35 to 85% RH		
<b>Storage temp / humidity</b>		-20 to 60 °C (-4 to 140 °F) , 35 to 85% RH		
<b>Environmental illuminance</b>		Incandescent lamp = Max 3,000 lux		
<b>Vibration resistance</b>		10 to 55 Hz double amplitude 1.5mm for XYZ		
<b>Shock resistance</b>		50G (500m/s <sup>2</sup> )		
<b>Cable</b>		50cm (19.7 inch) cable		
<b>Cable extension</b>		CD4CN-S-ROBOT (2m, 78 inch) , CD4CN-5S-ROBOT (5m, 197 inch)		
<b>Material</b>		Aluminum diecast		

\*1 Defined with center strength 1/e<sup>2</sup> (13.5%). There may be leak light other than the spot size. The sensor may be affected when there is a highly reflective object close to the detection area.  
 \*2 256 times in average (using the special amplifier), object: White ceramic. The value is subject to objects.  
 \*3 The typical value in the conditions of 256 times in average (using the special amplifier), object: White ceramic, distance range: Middle. The value is subject to objects.

## CD4L-25

Model	CD4L-25
<b>Measurement range</b>	25 ±1mm
<b>Light source</b>	Class 1 (IEC/JIS) CLASS II (FDA) Laser, 650nm, max 390 micro W
<b>Spot size</b> (*1)	25×35 μm
<b>Linearity</b> (*2)	± 0.1% F.S.
<b>Resolution</b> (*3)	0.1 μm
<b>Supply voltage</b>	Supplied by CD4A-LN/LP controller
<b>Temp drift</b>	±0.01% F.S. / °C
<b>Laser emission indicator</b>	Green = Laser emission
<b>Measurement indicator</b>	Red = In range, closer than center 5% of measurement range (0 to 45%)
	Orange = Within +/- 5% of the center of the measuring range
	Green = In range, farther than center 5% of measurement range (55 to 100%)
	Red/Green alternating = Out of measuring range
<b>Protection category</b>	IP67
<b>Operation temp / humidity</b>	-10 to 45 °C ( 14 to 113 °F) , 35 to 85% RH
<b>Storage temp / humidity</b>	-20 to 60 °C (-4 to 140 °F) , 35 to 85% RH
<b>Environmental illuminance</b>	Incandescent lamp = Max 3,000 lux
<b>Vibration resistance</b>	10 to 55 Hz double amplitude 1.5mm for XYZ
<b>Shock resistance</b>	50G (500m/s <sup>2</sup> )
<b>Cable</b>	50cm (19.7 inch) cable
<b>Cable extension</b>	CD4CN-S-ROBOT (2m, 78 inch) , CD4CN-5S-ROBOT (5m, 197 inch)
<b>Material</b>	Aluminum diecast

\*1 Defined with center strength 1/e<sup>2</sup> (13.5%). There may be leak light other than the spot size. The sensor may be affected when there is a highly reflective object close to the detection area.  
 \*2 256 times in average (using the special amplifier), object: White ceramic. The value is subject to objects.  
 \*3 The typical value in the conditions of 256 times in average (using the special amplifier), object: White ceramic, distance range: Middle. The value is subject to objects.

## Controller

Model	CD4A-N / -LN (NPN output type)	CD4A-P / -LP (PNP output type)
<b>Number of heads</b>	Max.2 pcs	
<b>Sampling period</b>	100μs	
<b>Supply voltage</b>	12 to 24V, DC ±10%	
<b>Power consumption</b>	270mA/24V (When connected with 2 sensor heads. Including analog current output)	
<b>Temp drift</b>	±0.01% F.S./ °C	
<b>Analog output</b>	<b>ANG (V) [A] [B]</b>	Voltage output ±5V / F.S. (Output impedance 100Ω, resolution 1mV)
	<b>ANG (mA) [A] [B]</b>	Current output 4 to 20mA / F.S. (Load impedance 300Ω, resolution 1.5μA)
<b>Alarm output</b>	<b>ALM A,ALM B</b>	NPN open collector / PNP open collector
		Max. 100mA / DC 24V (residual voltage Max. 1.8V) Turns ON when the sensor head fails in measurement.
<b>Control output</b>	<b>JDGE 1 to 5</b>	NPN open collector / PNP open collector
		Max. 100mA / DC 24V (residual voltage Max. 1.8V) HI / LO setting and Hysteresis setting are available for each output.
<b>Bank input</b>	<b>BANK 0 to 2</b>	ON when connected to GND / ON when connected to 12 to 24V
		8 banks selectable
<b>Hold input</b>	<b>HOLD A, HOLD B, HOLD RST</b>	ON when connected to GND / ON when connected to 12 to 24V
		Laser off or measurement value holding (selectable in the menu)
<b>Zero reset input</b>	<b>ZERO A, ZERO B</b>	ON when connected to GND / ON when connected to 12 to 24V
		Zero reset of head A measurement value / Head B measurement value / Calculation value is available.
<b>Optional features</b>	Average sampling times, Filter mode (Cut-off frequency), Calculation, Hold setting, Output during alarm, Output control (Hysteresis), Analog output, Sensor head sensitivity control, Timer function, Memory function, Memory bank function, Auto zero reset	
<b>Display type</b>	LCD display	
<b>Protection category</b>	IP20	
<b>Operation temp / humidity</b>	-10 to +45°C (Non-condensing) / 35 to 85% RH	
<b>Storage temp / humidity</b>	-20 to +60°C / 35 to 85% RH	
<b>Vibration resistance</b>	10 to 55Hz, Double amplitude 1.5mm, 2h for XYZ axis	
<b>Shock resistance</b>	20G (196m/s <sup>2</sup> )	
<b>Material</b>	Chassis: Polycarbonate, Connection terminals: Nylon 66	
<b>Weight</b>	240g (including connection terminals)	

# LINEARITY (Typical example data)

## CD4 series : by material

Model No. : CD4-30/CD4-30-3R

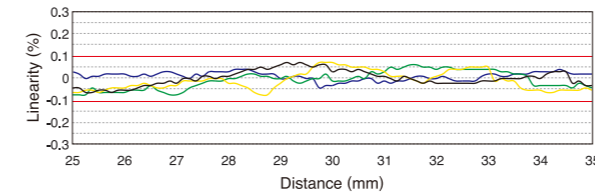

Model No. : CD4-85/CD4-85-3R

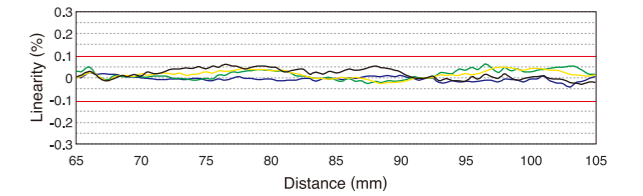

Model No. : CD4-350/CD4-350-3R

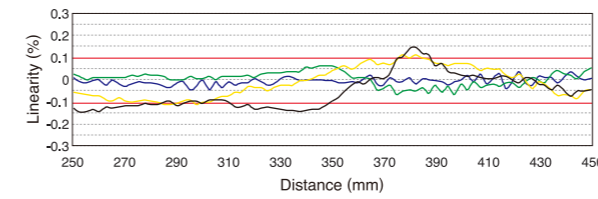

- White ceramic
- Aluminum
- Gray ceramic
- Black rubber

## CD4L-25 : by angle

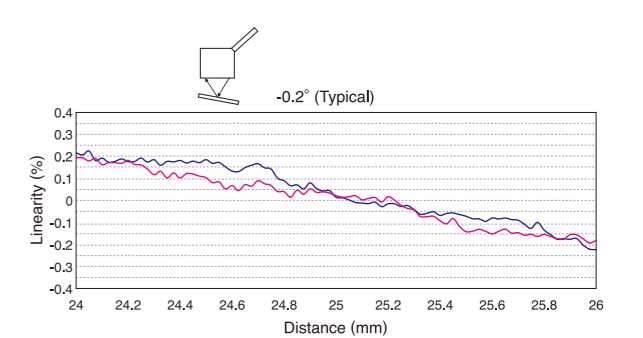
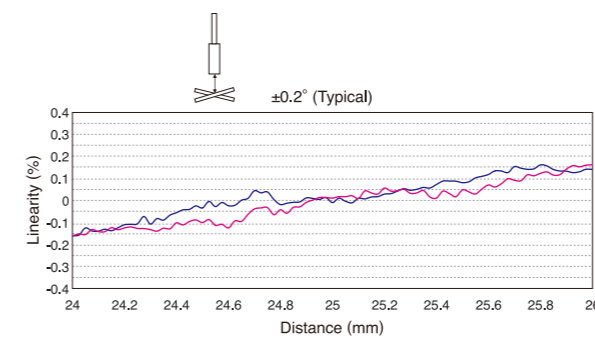
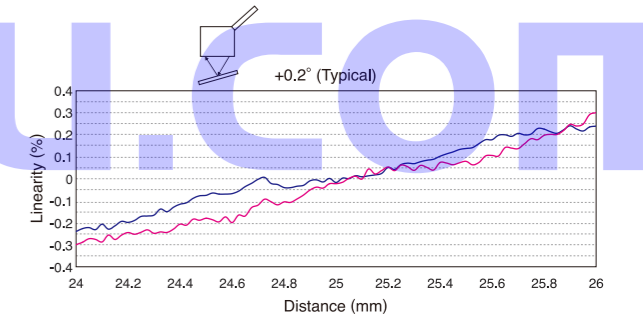
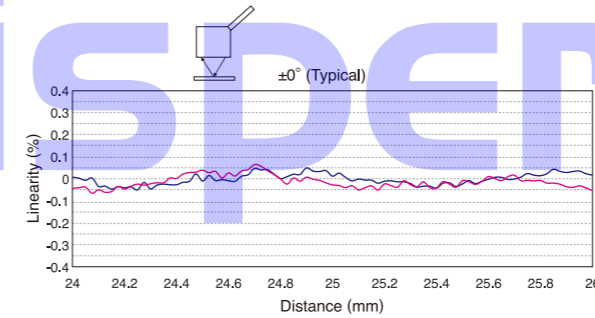

- Mirror(SENS=MIN)
- Glass(SENS=8)

# SPOT SIZE

## CD4 series

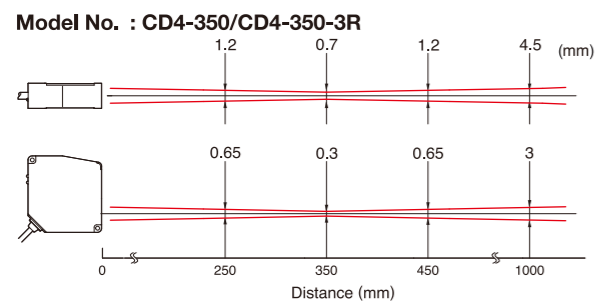
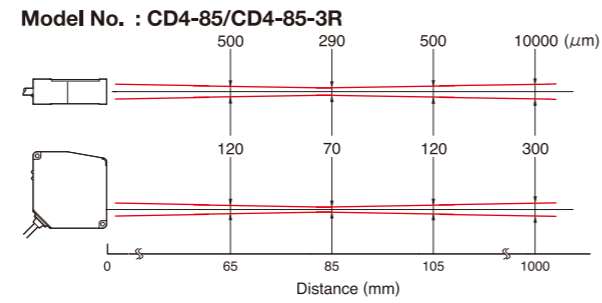
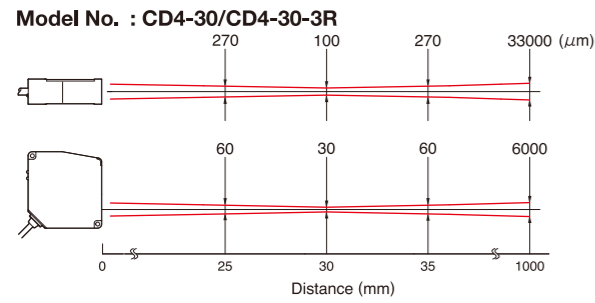

## CD4L-25

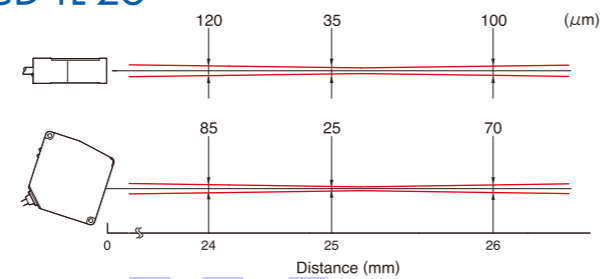

# INTERFERENCE AREA

## CD4 series

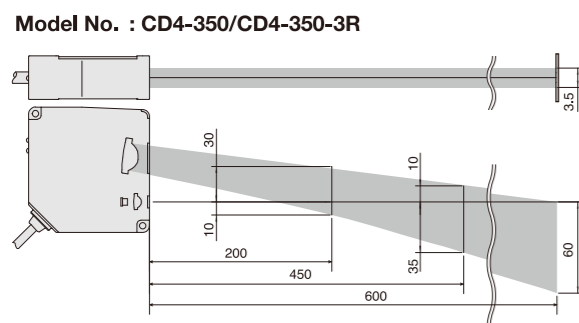
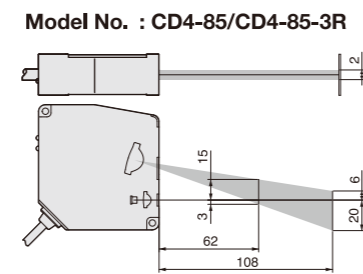
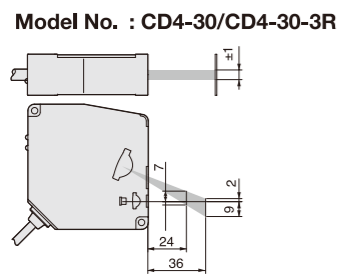

## CD4L-25

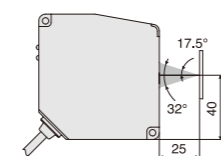

(mm)

# INPUT / OUTPUT DIAGRAMS

**NPN model bank input  
Hold input  
Zero reset input**

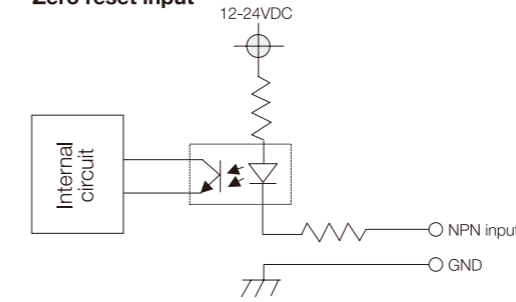

**NPN model control output  
Alarm output**

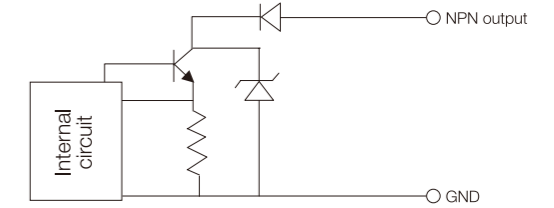

**PNP model bank input  
Hold input  
Zero reset input**

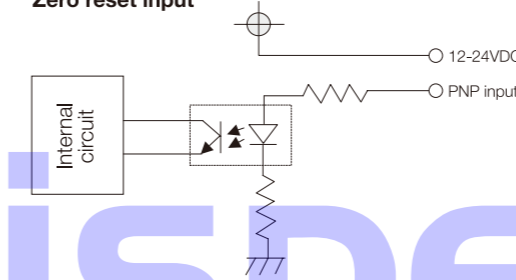

**NPN model control output  
Alarm output**

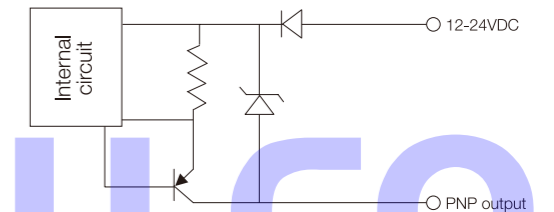

**Analog output (A/B)**

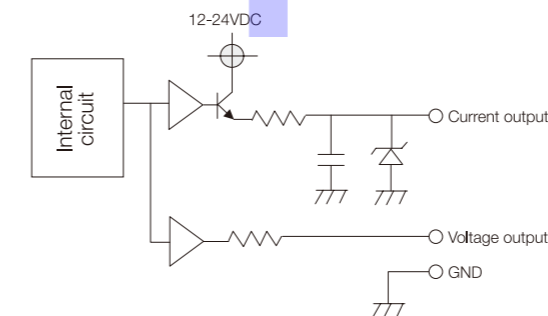



# CD33 series

CMOS sensor with  $\pm 0.1\%$  F.S. linearity packed in a half-palm size.

- Compact design ideal for builtin use with OEM machines.
- Analogue output (4-20mA or 0-10V) + 2 control outputs
- Stand-alone design capable of direct operation without controller

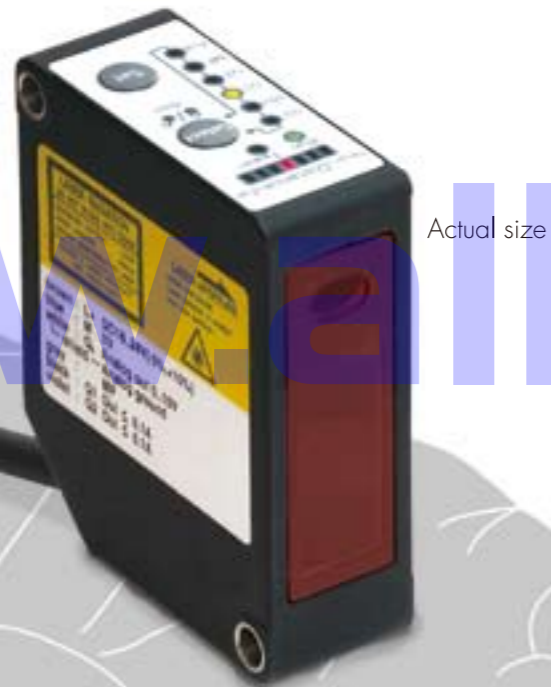

Actual size

## LINEUP

### CD33-30NV (PV) CD33-30NA (PA)

**30mm distance type**

Warping / Sagging of PC board

Measurement range : 30  $\pm$ 4mm  
Resolution : 4  $\mu$ m (Fast mode)  
Linearity :  $\pm 0.1\%$  F.S.

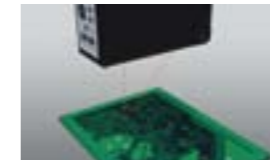

### CD33-50NV (PV) CD33-50NA (PA)

**50mm distance type**

Height of components on the board

Measurement range : 50  $\pm$ 10mm  
Resolution : 8  $\mu$ m (Fast mode)  
Linearity :  $\pm 0.1\%$  F.S.



### CD33-85NV (PV) CD33-85NA (PA)

**85mm distance type**

Joint of rubber sheet

Measurement range : 85  $\pm$ 20mm  
Resolution : 15  $\mu$ m (Fast mode)  
Linearity :  $\pm 0.1\%$  F.S.



### CD33-120NV (PV) CD33-120NA (PA)

**120mm distance type**

Loosen rubber sheet

Measurement range : 120  $\pm$ 60mm  
Resolution : 45  $\mu$ m (Fast mode)  
Linearity :  $\pm 0.1\%$  F.S.



**Product code**

- CD33-□□ **NV** (N=NPN, V=0-10V)
- CD33-□□ **NA** (N=NPN, A=4-20mA)
- CD33-□□ **PV** (P=PNP, V=0-10V)
- CD33-□□ **PA** (P=PNP, A=4-20mA)



Teléfonos: 628-0810 / 628-0811  
Fax: 4627136  
Nextel: 832\*8591 / 832\*7745  
WEB [www.alltronicsperu.com](http://www.alltronicsperu.com)

Calle Manco Capac 125 Ofic. 102 Magdalena del Mar Lima - Perú

# CD33 ADVANCED TECHNOLOGY

The CD33 series is a function rich CMOS laser displacement sensor designed in an ultra-compact housing

## Just 65g weight.

Stand-alone design dedicates space-saving as well as cost-saving. No separate controller required and thanks to the light weight, the CD33 is ideal for installations on robot end effectors.



## Ideal for robot mounting

Ideal for mounting on robot cylinder thanks to compact dimensions and the light 65g weight. IP67 water tightness is also secured.



## Digital subpixel processing

Subpixel processing divides one pixel into small pieces that enables accurate measurement by reproducing genuine value of incoming light.

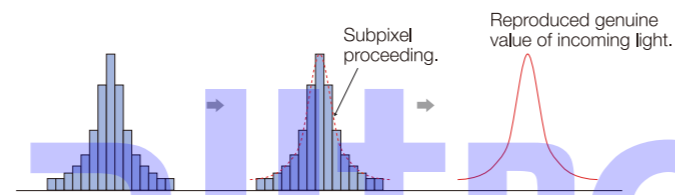

## Easy operation

Just two buttons (SET and SELECT) are enough to set and operate. LED indicator shows which function you are setting.



## High resolution electronic shutter

High resolution electronic shutter controls to keeps a constant level according to reflection. This function enables stable peak level detection even when unstable surface conditions exist.

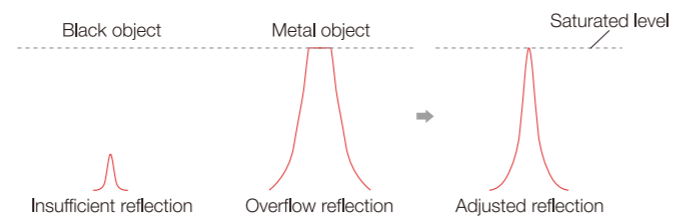

## 2CH outputs enables individual setting of measurement range.

Highly accurate comparator output capable of identifying 12μm (with CD33-30 types). Hysteresis is just 0.15% F.S.



## Easy-to-select models between voltage and current output.

It is common today for sensors to be very complicated requiring long set-up times and many buttons to operate. The CD33 focuses on easier set-up by separating voltage and current output models into two types.

### 4-20mA output + 2CH outputs

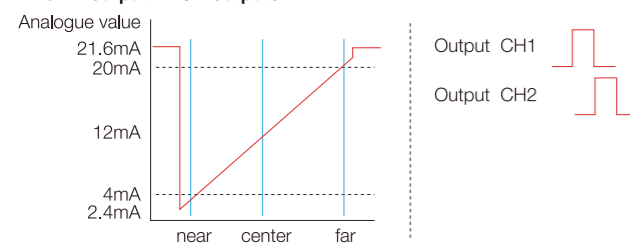

### 0-10V output + 2CH outputs

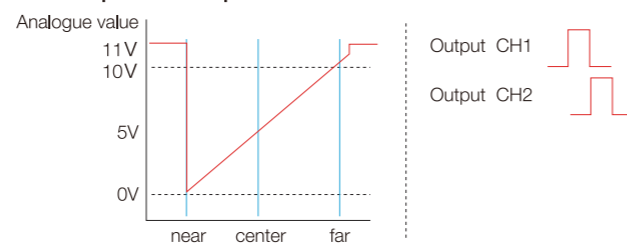

# DIMENSIONS

## Cable type

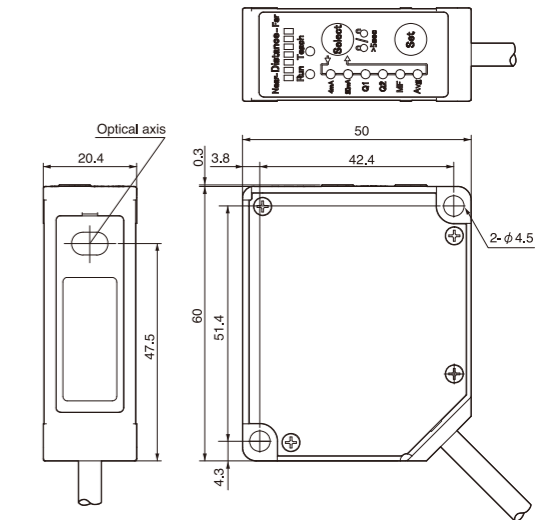

## M12 Connector type

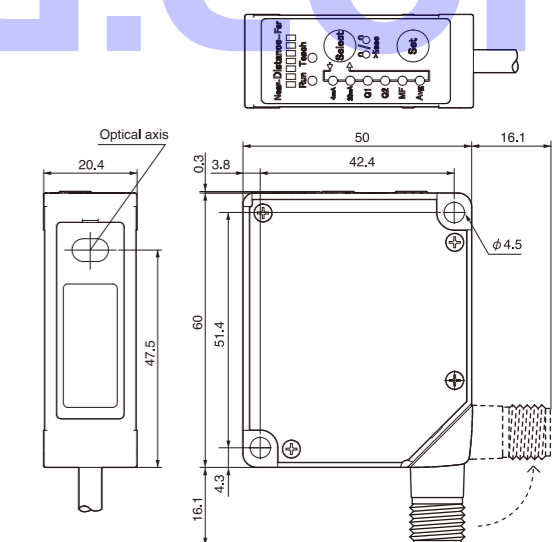

Connector pinout

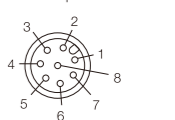

(mm)

## MF (Multi Function) input for further convenience.

The programmable remote MF input can be set to one of the following: Laser o, External teach, Hold, or One-shot trigger.



# SPECIFICATIONS

Model	Cable type	2control output				
		CD33-30N / P	CD33-50N / P	CD33-85N / P	CD33-120N / P	
		2control output + Analog 4-20mA	CD33-30NA / PA	CD33-50NA / PA	CD33-85NA / PA	CD33-120NA / PA
		2control output + Analog 0-10V	CD33-30NV / PV	CD33-50NV / PV	CD33-85NV / PV	CD33-120NV / PV
		1control output + RS422	CD33-30N-422 / P-422	CD33-50N-422 / P-422	CD33-85N-422 / P-422	CD33-120N-422 / P-422
Connector type		2control output	CD33-30CN / CP	CD33-50CN / CP	CD33-85CN / CP	CD33-120CN / CP
		2control output + Analog 4-20mA	CD33-30CNA / CPA	CD33-50CNA / CPA	CD33-85CNA / CPA	CD33-120CNA / CPA
		2control output + Analog 0-10V	CD33-30CNV / CPV	CD33-50CNV / CPV	CD33-85CNV / CPV	CD33-120CNV / CPV
		1control output + RS422	CD33-30CN-422 / CP-422	CD33-50CN-422 / CP-422	CD33-85CN-422 / CP-422	CD33-120CN-422 / CP-422

<b>Control output</b>		N = NPN output, P = PNP output			
<b>Measurement range</b>		30±4mm	50±10mm	85±20mm	120±60mm
<b>Full scale</b>		8mm	20mm	40mm	120mm
<b>Light source</b>		Red laser diode (wave length 650nm)			
<b>Peak power</b>		1mW max.			
<b>IEC/JIS Class</b>		Class 2			
<b>FDA CLASS</b>		CLASS II			
<b>Spot size (approx.volume) (*1)</b>	<b>Near</b>	0.15x0.15mm	0.6x1.2mm	0.9x1.5mm	1.2x1.8mm
	<b>Middle</b>	0.1x0.1mm	0.5x1.0mm	0.75x1.25mm	1.0x1.5mm
	<b>Far</b>	0.15x0.15mm	0.4x0.9mm	0.6x1.0mm	0.5x0.8mm
<b>Linearity (*2)</b>		±0.1% F.S.			
<b>Resolution (*3)</b>	<b>Fast</b>	4μm	8μm	15μm	45μm
	<b>Other</b>	2μm	5μm	10μm	30μm
<b>Supply voltage</b>		12 - 24V DC (-5 to +10%)			
<b>Temp drift</b>		±0.08%F.S. / °C			
<b>Response time (*4)</b>	<b>Fast</b>	1ms+ selecting sensitivity (averaging: 1)			
	<b>Standard</b>	8.5ms+ selecting sensitivity (averaging: 16)			
	<b>High resolution</b>	32.5ms+ selecting sensitivity (averaging: 64)			
	<b>Selecting sensitivity</b>	4ms max.			
<b>Indicators</b>	<b>Distance indicator</b>	bar graph LED			
	<b>Output indicator</b>	ON status : Orange			
<b>Protection category</b>		IP67			
<b>Operating temp / humidity</b>		-10~+45°C / 35~85%RH (No condensation or freezing)			
<b>Storage temp / humidity</b>		-20~+60°C / 35~95%RH (No condensation or freezing)			
<b>Ambient illuminance</b>		Sun light: 10,000lx max. Incandescent lamp: 3,000lx max.			
<b>Vibration resistance</b>		10 to 55 Hz, Double amplitude 1.5 mm, 2 h for XYZ axes			
<b>Shock resistance</b>		50G (500m/s <sup>2</sup> )			
<b>Material</b>		PBT (Case) PMMA (Front window)			
<b>Weight</b>	<b>Cable type</b>	approx.65g (without cable)			
	<b>Connector type</b>	approx.70g			

Model	2 Control output	+ Analog 4-20mA	+ Analog 0-10V	2 Control output + RS422
<b>Supply voltage</b>	DC 12-24V (-5%, +10%)		DC 18-24V (-5%, +10%)	DC 12-24V (-5%, +10%)
<b>Current consumption</b>	max. 75mA (DC24V)		max. 80mA (DC24V) including analog output	
<b>Output</b>	<b>Control output 1</b>	NPN / PNP open collector 100mA max. / 30VDC (residual voltage max. 1.8V)		—
	<b>Control output 2</b>	NPN / PNP open collector 100mA max. / 30VDC (residual voltage max. 1.8V)		—
	<b>Analog output</b>	—	4-20mA	0-10V
<b>Interface</b>	—			RS422
<b>Cable type</b>	Dia : 5mm 5core 2m AWG24 (PVC)		Dia : 5mm 6core 2m AWG24 (PVC)	
<b>Connector type</b>	M12 8pin			

\*1 Defined with center strength 1/e<sup>2</sup> (13.5%). There may be leak light other than the specified spot size. The sensor may be affected when there is a highly reflective object around the targets.  
 \*2 Averaging: 64 (High resolution), Object: white ceramic.  
 \*3 Middle of measuring range, Object: white ceramic.  
 \*4 Response time : response time plus selecting sensitivity time.

# SPOT SIZE

Model No. : CD33-30N □

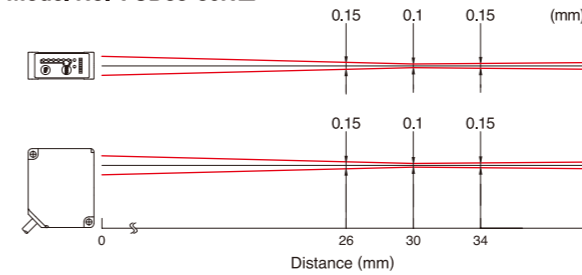

Model No. : CD33-50N □

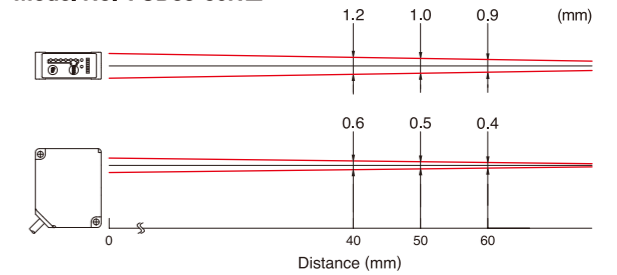

Model No. : CD33-85N □

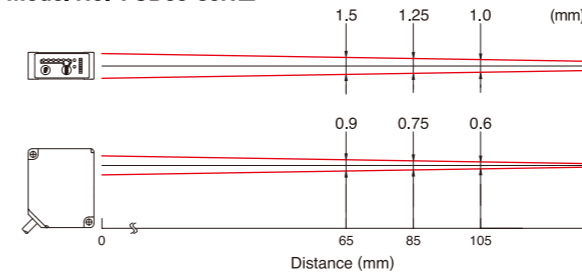

Model No. : CD33-120N □

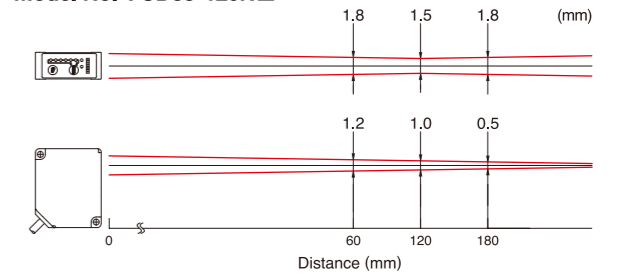

# INPUT / OUTPUT DIAGRAMS

NPN type (Analogue/Voltage dual)

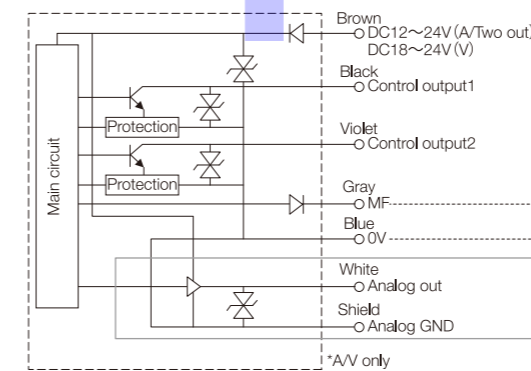

NPN type (RS422)

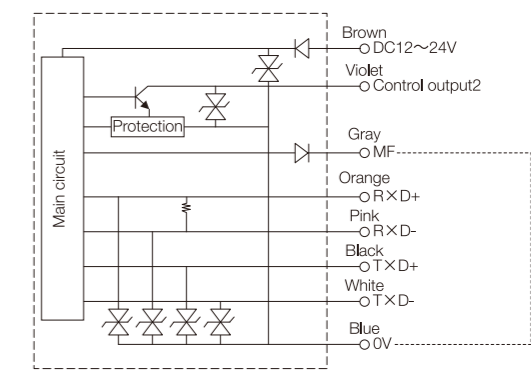

PNP type (Analogue/Voltage dual)

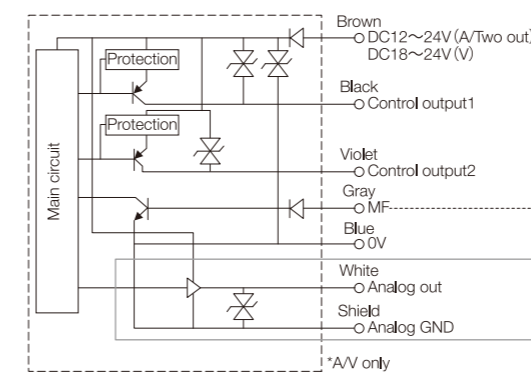

PNP type (RS422)

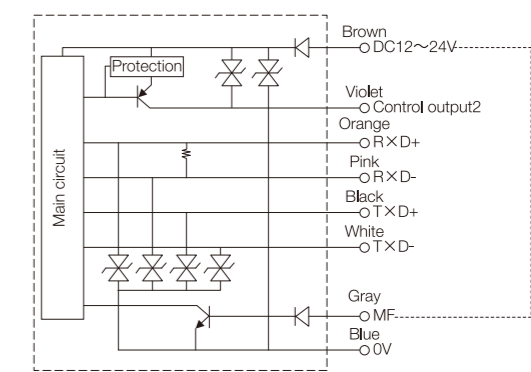

# CD3 series

- CMOS Image sensor for high accuracy displacement laser.
- Span adjustment and offset functions for flexible control of analogue output.
- Preset alarm for Peak / Bottom limit of analogue value.
- Accurate detection of dark colored targets.

## LINEUP

### CD3-30

#### 30mm type

Warp detection of PC board

Measurement range : 30 ±4mm  
Resolution : 2 μm (When averaging of 256 times)  
Linearity : ±1% F.S.

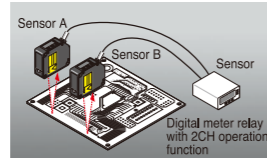

### CD3-50

#### 50mm type

Warp detection of HDD assy and actuator

Measurement range : 50 ±10mm  
Resolution : 8 μm (When averaging of 256 times)  
Linearity : ±1% F.S.

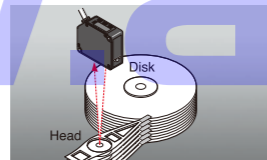

### CD3-80

#### 80mm type

Interior diameter of gear

Measurement range : 80 ±15mm  
Resolution : 8 μm (When averaging of 256 times)  
Linearity : ±1% F.S.

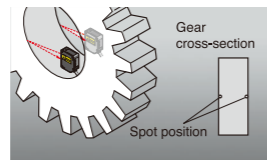

### CD3-100

#### 100mm type

Measurement of product thickness

Measurement range : 100 ±40mm  
Resolution : 30 μm (When averaging of 256 time)  
Linearity : ±1% F.S.

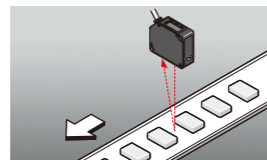

### CD3-250

#### 250mm type

Monitoring die cast

Measurement range : 250 ±150mm  
Resolution : 100 μm (When averaging of 256 time)  
Linearity : ±1.5% F.S. (100 to 250mm)  
±2.5% F.S. (251 to 400mm)



# CD3 ADVANCED TECHNOLOGY

Simple pushbutton teach, and easy-to-view digital panel.

Simple pushbutton teach, and easy-to-view digital panel.

**stability indicator**

- Green — Stable operation
- Dark — Unstable operation
- Red — No operation due to low light or too much light

**distance indicator**

Actual distance between sensor and object as below.

green / red blinking	Out of range
red	Near limit
orange	±5% of reference distance
green	Far limit
red / green blinking	Out of range

Remarks : The border between the near / far limit and out of range depends upon the sensor model.

**output indicator**

**(operation panel)**

- Run indicator
- Function indicator
- Adjustment indicator
- Down
- Up
- Mode selection

Stable measurement of both highly reflective polished surfaces as well as non reflective material such as black rubber.

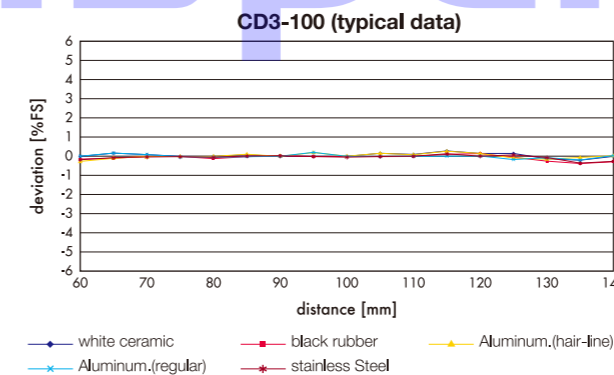

## Offset

The Offset Function shifts the analog output value in either the positive or the negative direction. This is adjustable within ±50% of the rated distance of the sensor.

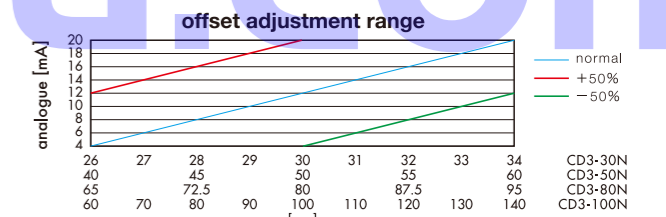

## Span adjustment

Span adjustment changes the proportion of output value (displacement) to the distance. This is available within ±50% against rated value.

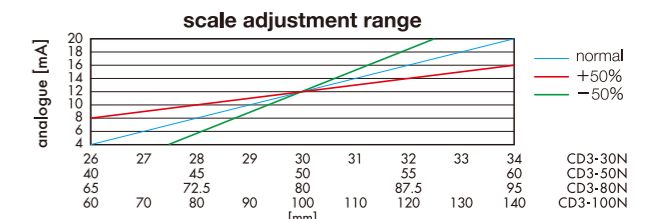

## Voltage output coverter CV-15

If you need to convert 4-20mA analogue output into 1-5V voltage output connect the resistor CV-15.

### Digital Meter, etc

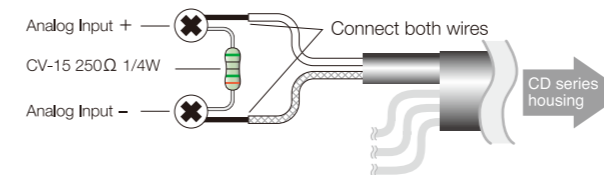

photo : CV-15



## Analogue restraint function

In case analogue value overflows the limit, you can choose ; CLP mode = Analogue value remains 24mA for any overflowing value.

HOLD mode = Analogue value is held at the last value before overflow.

# DIMENSIONS

## Cable type

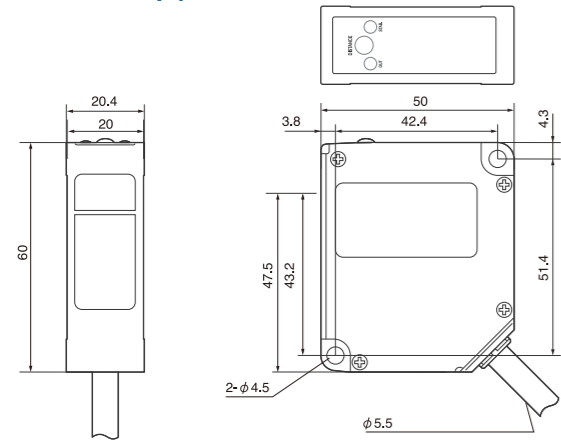

## M12 Connector type

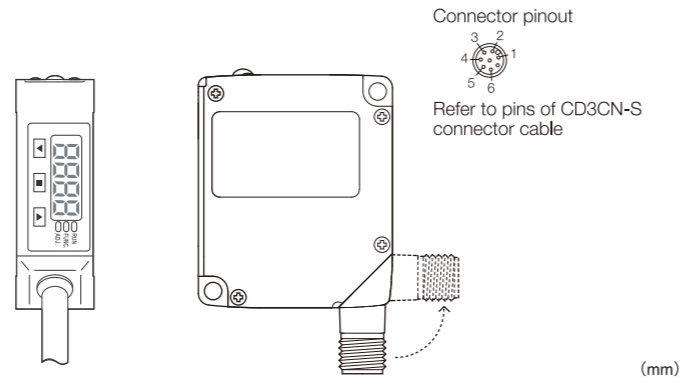

# SPECIFICATIONS

Model	Cable M12 Connector	CD3-30N/P	CD3-50N/P	CD3-80N/P	CD3-100N/P	CD3-250N/P
		CD3-30CN/CP	CD3-50CN/CP	CD3-80CN/CP	CD3-100CN/CP	CD3-250CN/CP
<b>Transistor output</b>	N = NPN output, P = PNP output					
<b>Measurement range</b>		30 ±4mm	50 ±10mm	80 ±15mm	100 ±40mm	250 ±150mm
<b>Full scale</b>		8mm	20mm	30mm	80mm	300mm
<b>Light source</b>	Class 2 Laser, 650nm, max 1mW					
<b>Min spot size</b>		φ@0.5 mm	φ@0.8 mm	1×1.5mm	1×1.5mm	3×1.5mm
<b>Supply voltage</b>	12 - 24V DC (-5 to +10%)					
<b>Sensitivity adjustment</b>	Nominal value 1-20, or AUTO					
<b>Power consumption</b>	Max 120mA (DC12V), 80mA (DC24V), including analog output current					
<b>Resolution (typical value)</b>	(Unit : Micron. Under AUTO sensitivity. White ceramic as an object)					
<b>(Averaging 64: default value)</b>		4	10	10	30	150
<b>(Averaging 1)</b>		12	30	40	80	2mm
<b>(Averaging 4)</b>		8	20	30	60	800
<b>(Averaging 16)</b>		6	12	20	40	400
<b>(Averaging 256)</b>		2	8	8	20	100
<b>(Averaging 1024)</b>		below 2	below 8	below 8	below 10	50
<b>Linearity</b>		±1% F.S.				±1.5%F.S. (up to 250mm) ±2.5%F.S. (up to 400mm)
<b>Temp drift</b>	±0.08% F.S. / Celsius					
<b>Response time</b>	Max 2.2ms (at fixed sensitivity between 1-20), Max 15ms (at auto sensitivity)					
<b>Sampling rate</b>	500μs					
<b>Analogue output</b>	4-20 mA					
<b>Control output</b>	NPN or PNP, Max 100mA/DC24V, Residual voltage max 1.8V					
<b>Timer</b>	On delay / Off delay / Oneshot (1msec increment for 0-999ms, 1sec for 0-10 sec)					
<b>Distance indicator</b>	Red = Near, Orange = Middle, Green = Far, Red/Green = Error *Remark : Errors as "out of measuring range", "Too high reflection", etc					
<b>Stability indicator</b>	Green = Stable, Red = Error, No light = Unstable, need adjustment					
<b>Control output indicator</b>	Orange = Output (NPN or PNP)					
<b>Environmental illuminance</b>	Sun light : Max 10,000 lux, Incandescent Lamp = Max 3,000 lux					
<b>Operating temp / humidity</b>	-10 to 40°C, 35 to 95% RH					
<b>Insulation resistance</b>	20 MΩ / DC 500V					
<b>Material</b>	Zinc diecast					
<b>Protection category</b>	IP67					
<b>Conformity</b>	CE					
<b>Warm-up time</b>	30 minutes					
<b>Weight</b>	Approx.130g (Without cable)					

# CD1 series

- Compact design ideal for built-in use with OEM machines.
- Versatility from 30 ±4mm to 250 ±150mm distance.
- If a display and signal control is needed both the digital and analog output of the CD1 can be connected to a digital panel meter.

## LINEUP

### CD1-30

**30mm distance type**  
Sorting of mechanical parts

Measurement range : 30 ±4mm  
Resolution : 1 μm (Response speed 100msec)  
Linearity : ±2% F.S.



### CD1-50

**50mm distance type**  
Level check of food package

Measurement range : 50 ±10mm  
Resolution : 3 μm (Response speed 100msec)  
Linearity : ±1% F.S.



### CD1-100

**100mm distance type**  
Height of components on the board

Measurement range : 100 ±35mm  
Resolution : 15 μm (Response speed 100msec)  
Linearity : ±2% F.S.



### CD1-130

**130mm distance type**  
Cap of bottled beverage

Measurement range : 130 ±50mm  
Resolution : 20 μm (Response speed 100msec)  
Linearity : ±3.5% F.S.



### CD1-250

**250mm distance type**  
Doubled part of black rubber sheet

Measurement range : 250 ±150mm  
Resolution : 150 μm (Response speed 100msec)  
Linearity : ±5% F.S.



# CD1 ADVANCED TECHNOLOGY

All the basic functions packed in a half-plam size, ideal for OEM use.

## Teach-in system

The CD1 is simple to setup and easy to operate. It is not necessary to make manual adjustments to the sensor, just push the button.



## All-in-one solution

The amplifier and sensor are built-in, the CD1 is a complete self-contained sensor.



## Remote teaching input

The teaching procedure can be carried out remotely by using the remote teach input. There is no need to perform this step at the sensor. This feature is good for OEM machine builders.

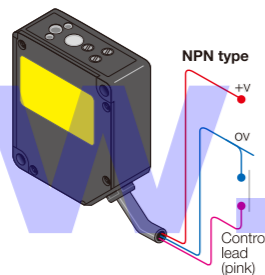

## Dual output - Digital On/Off and analog

There is a choice of NPN or PNP transistor for the control output, choose the model number based on the desired type. The 4 to 20 mA analog output is standard on both types.

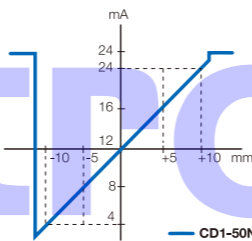

## Easy set-up and measuring

The high and low limit of the measuring range can be set.

- 1: Go to the SET mode.
- 2: Teach the high and low limit using the workpiece.
- 3: Return to RUN mode.

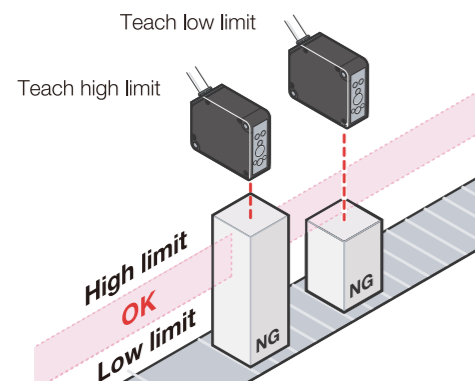

## Class 2 laser product

Classified to Class 2 laser, 650nm, max 1mW.



## IP67 rating

This stand-alone unit is protected with IP67 design.



# DIMENSIONS

## Cable type

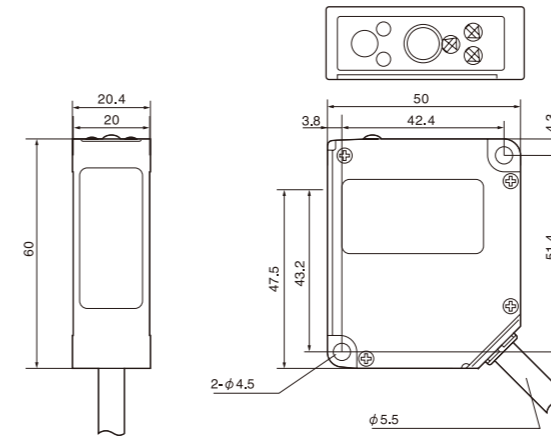

## M12 Connector type

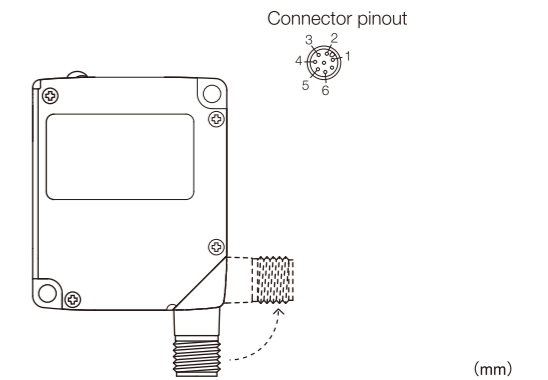

# SPECIFICATIONS

Model	Cable	CD1-30N/P	CD1-50N/P	CD1-100N/P	CD1-130N/P	CD1-250N/P
	M12 Connector	CD1-30CN/CP	CD1-50CN/CP	CD1-100CN/CP	CD1-130CN/CP	CD1-250CN/CP
<b>Transistor output</b>		N = NPN output, P = PNP output				
<b>Measurement range</b>		30 ±4mm	50 ±10mm	100 ±35mm	130 ±50mm	250 ±150mm
<b>Full scale</b>		8mm	20mm	70mm	100mm	300mm
<b>Light source</b>		Class 2 laser, 650nm, max 3.3mW				
<b>Spot size</b>		φ0.1mm	φ0.5mm	0.5×1.2 mm	0.5×1.5 mm	0.8×1.2 mm
<b>Supply voltage</b>		12 - 24V DC (-5 to +10%)				
<b>Power consumption</b>		Max 120mA (DC12V), 75mA (DC24V), including analog output current				
<b>Resolution (typical value)</b>		(Unit : Micron. Under AUTO sensitivity. White ceramic as an object)				
<b>(Response speed 100msec)</b>		1	3	15	20	150
<b>(Response speed 10msec)</b>		3	10	50	70	500
<b>(Response speed 1msec)</b>		10	30	150	200	1500
<b>Linearity</b>		±2% F.S.	±1% F.S.	±2% F.S.	±3.5% F.S.	±5% F.S.
<b>Temp drift</b>		±0.02% F.S. / Celsius				
<b>Response time</b>		100msec / 10msec / 1msec selectable				
<b>Sensitivity adjustment</b>		SET / FIX / AUTO				
<b>Analogue output</b>		4-20mA				
<b>Control output</b>		NPN or PNP, Max 100mA/DC30V, Residual voltage max 1.8V				
<b>Distance indicator</b>		Red = Near, Orange = Middle, Green = Far, Red/Green = Error *Remark : Errors as "out of measuring range", "Too high reflection", etc				
<b>Stability indicator</b>		Green = Stable, Red = Error, No light = Unstable, need adjustment				
<b>Output indicator</b>		Orange = Output				
<b>Teach-in indicator</b>		Green = Input, Red = Error				
<b>Blanking input</b>		NPN = Gray wire to 0V, PNP = Gray wire to +V				
<b>Delay function</b>		Off delay 40msec				
<b>Environmental illuminance</b>		Sun light : Max 10,000 lux, Incandescent Lamp = Max 3,000 lux				
<b>Operating temp</b>		-10°C to 40°C				
<b>Operating humidity</b>		35% to 95% RH				
<b>Material</b>		Zinc diecast				
<b>Protection category</b>		IP67				
<b>Conformity</b>		CE				
<b>Warm-up time</b>		30 minutes				
<b>Weight</b>		Approx.130g (Without cable)				